HAND HELD PROGRAMMER QUICK START GUIDE

IMPORTANT INFORMATION

1) Do not leave the programmer connected to the PC adapter or a target system, as this will drain the battery.

LOADING FROM THE PC

1) Connect the PC adapter (dongle) to the PC parallel port.

2a) Connect the long extension cable, using the end black socket, to the PC adapter. Then connect the programmer to the end grey plug of the extension cable - using the short ribbon cable. This method is useful where access to the PC adapter is poor.

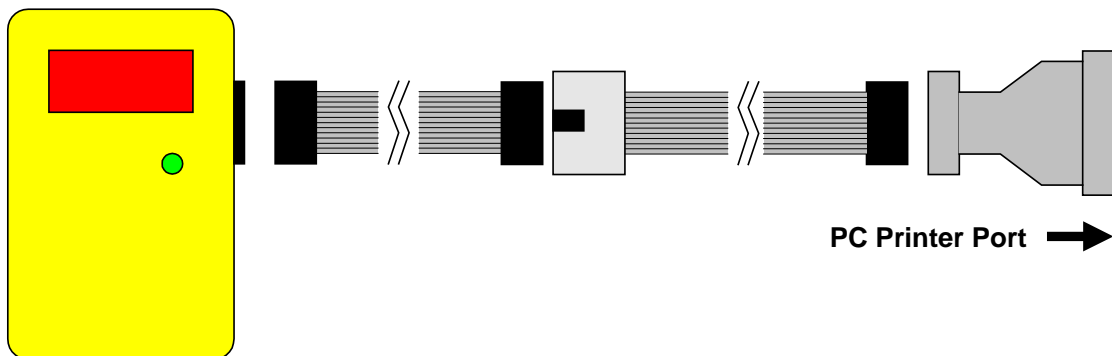

2b) Or, simply connect the PC adapter directly to the programmer using the short ribbon cable.

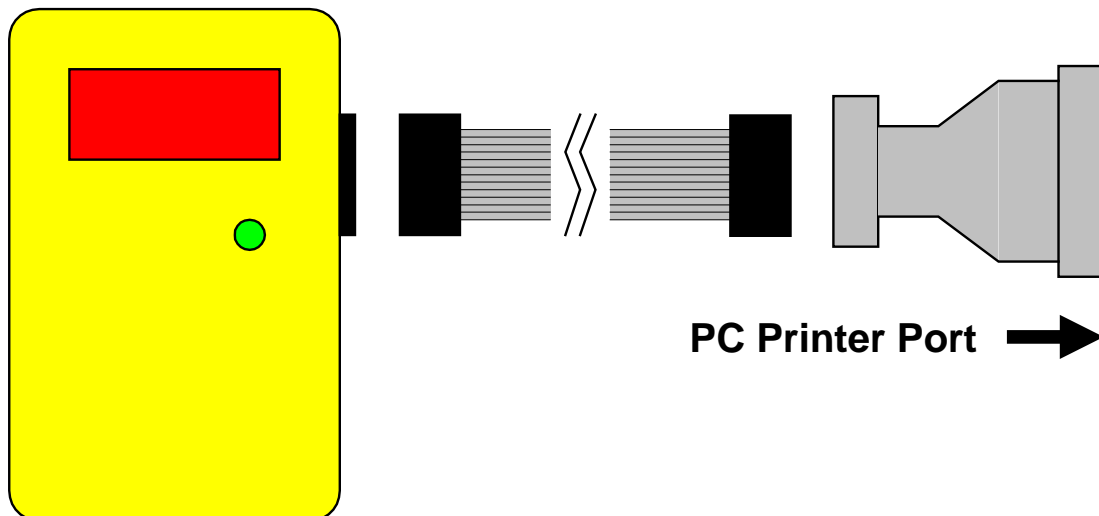

3) Install and Run the Handheld Programmer software

- Select the AVR device you want to use on the device screen
- The next screen allows you to select whether the Fuses (not Lockbits which will always appear) should be programmed. Check the **Fuse Enable** box to program fuses.

Notes:

- The whole AVR is erased (Flash and EEPROM) when a Flash file is selected
- To preserve the EEPROM data, the EESAVE fuse must be enabled. This fuse prevents the EEPROM from being erased. Do not select an EEPROM file if you want to keep EEPROM data
- To program EEPROM only, select an EEPROM file but no Flash file. This will NOT work if device is locked.
Note: The EEPROM is not fully erased, so if your new data is smaller than the existing data in the EEPROM, some of the old data will be left. To avoid this happening, add data to the end of the EEPROM buffer (last location not 0xFF).
- Fuses can be programmed before erase – see *below*. This means you can set the EESAVE fuse to preserve EEPROM data if it is not already set. Again this will not work if device is locked.
- The next screens are Lockbits followed by Fuses (if Fuse Enable is checked).

Notes:

DWEN (Debugwire Enable) and **RSTDISBL** (Reset Disable) Fuses are omitted because setting either of these fuses disables further serial programming of the AVR. Contact support if you need to set these fuses.

- The screen after Fuses screen is for Startup Time and Bootblock settings.
- The next screen is for setting the **target voltage**.
Notes:
This setting will change depending on whether the target is powered or not. See *section below on Power Options*. As a general rule:
 - 1) If Programmer powers target, set voltage to required target voltage
 - 2) If target is powered and Vcc is connected to ISP header, set voltage to 0V
 - 3) If target is powered and Vcc is **NOT** connected to ISP header, set voltage to match target voltage – Vcc

- The next screen is more programmer settings

Notes:

- Speed Settings: The programmer should work on **Fastest** setting unless you have a very slow clock (<1MHz) or you have capacitors on programming lines. If you get programming errors when using the programmer, try a slower setting.
- Check **Program fuses before erase** if you want to alter behaviour, e.g. set EESAVE fuse.

- Almost there! On the next screen, make sure that the LPT port you select is the one the PC adapter is using. The time selection on this screen allows error light to stay on for a shorter or longer time, default 5 seconds.

Note:

The error code (1, 2, 3 etc. flashes – see *below*) will repeat once a second, for as long as this time – default 5 seconds.

- On the last screen, click the **Upload** button to load the handheld programmer.

You Programmer is now loaded and ready for use.

If you get errors when loading the Handheld Programmer, please see *Troubleshooting* section.

PROGRAMMING A TARGET

1) Connect the programmer to the target system using the short ribbon cable.

- Target Layout – not end of lead view
- Header is 0.1" (2.54mm) box header in 5 x 2 format, with polarising notch
- See section below for *Six Way adapters*
- GND* These pins must be connected to target ground
- GND One or both must be connected to Target ground



POWER OPTIONS

There are three power options with the Handheld Programmer

1) Programmer powers target

Plug into unpowered target. Connector pin 2 (Vcc) must be connected to Vcc on your board and all 4 GND pins must be

connected to target ground. Use battery or external PSU. **There is a 150mA current limit for powering the target.**

In Software, select Vcc needed by target circuit on Target Voltage screen (0-5V)

2) Target Powered and Vcc connected to ISP Header

If target Vcc is connected to ISP header – Pin 2, then *Set voltage in software, on Target Voltage Screen, to 0V (or less than target voltage)*. All 4 GND pins must be connected and target must be powered.

3) Target Powered and Vcc NOT connected to ISP header

If target Vcc line is NOT connected to Pin 2 – Vcc on ISP header, *In Software, select Vcc on Target Voltage screen (0-5V) to match target circuit voltage*. Do connect all four GND pins to target ground. Power Target

Recommended ISP Circuit

This diagram shows a typical ISP circuit that will work with the Handheld Programmer. Please read the notes for more detail.

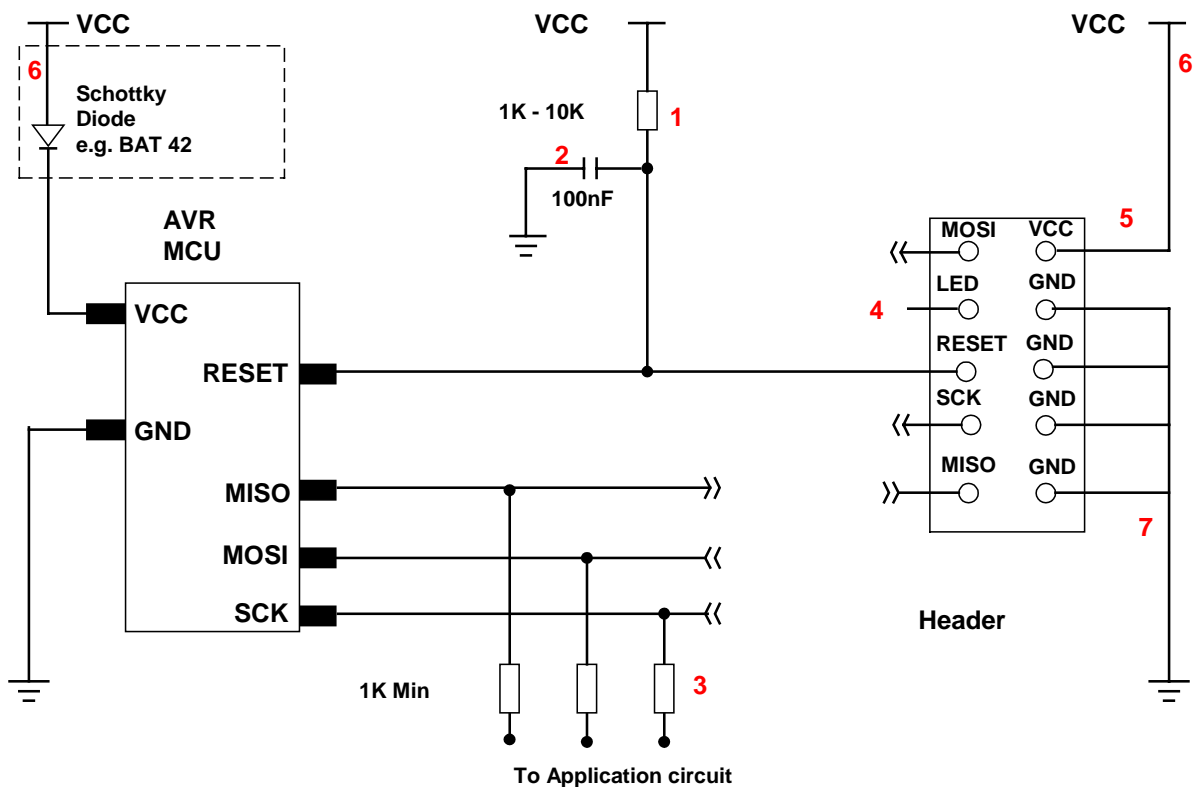

- 1) This resistor should be fitted. It can larger than 10K if required, but not smaller than 1K

- 2) Again 100nF is a typical value. We suggest a minimum of 10nF.
 - 3) Programming lines should be isolated from application circuit with series resistors, especially if application circuits force the state of the AVR pins. In exceptional cases, a multiplexer may be needed to isolate these lines. Capacitors on these lines may mean that a slower programming speed should be selected.
 - 4) Optional LED line. This can be connected to an indicator LED if desired, or used to drive a multiplexer. It is LOW during programming
 - 5) If Vcc is not connected to header, see *Power Options* section for programmer setup.
 - 6) If the programmer is powering the target, it is current limited to 150mA. If the rest of your circuit draws too much current, then fit this diode, and connect VCC to header and AVR through it.
 - 7) GND pins. We recommend that all GND pins are connected. If not, then either pin 4 or pin 10 MUST be connected – these are programmer Ground. Pin 6 is connected to programmer battery and **must be connected**. Pin 8 MUST be connected as it is the mode pin. The programmer uses this pin to check if it is connected to a PC or a target.
-

2) Press the button to start programming.

3) LED Codes

Normal operation:

A single green flash (red on v1.06), when first connected. Then, after pressing the button, the LED turns green for the duration of programming. At the end of programming the green LED switches off, and the target system is powered down.

If there was an error, the LED will flash RED. These codes repeat once a second, so do not confuse a single flash repeated 5 times with 5 flashes!

Error code – LED turns red:

- | | |
|------------------|--|
| 1 flash | - device not responding |
| 2 flashes | - erase failed |
| 3 flashes | - program failed |
| Constant Red LED | - Low battery or Over-Current trip > 150MA |
-

SIX WAY ADAPTERS

Because of the need to connect more than 1 GND pin, the adapter should connect GND pins together. So, the adapter is not as straight forward as it first appears.

Adapters from the 10-way DIL interface to 6-way flying leads, 6-way DIL (3 x 2 0.1" pin header), and 6-way Micromatch connectors are available from Kanda.

Order Codes are:



USING PC ADAPTER WITH AVRISP SOFTWARE

During code development, you may find it convenient to only have one PC adapter for both the Handheld Programmer and AVRISP software, so we have made the Handheld Programmer PC Adapter compatible with both.

- 1) Connect the PC adapter (dongle) to the PC parallel port.
- 2) Connect the extension cable to the PC adapter (single socket end).
- 2) Connect the extension cable to the target system, using the middle black socket.

NB AVR ISP software is not supplied with the Handheld Programmer Starter Kit.

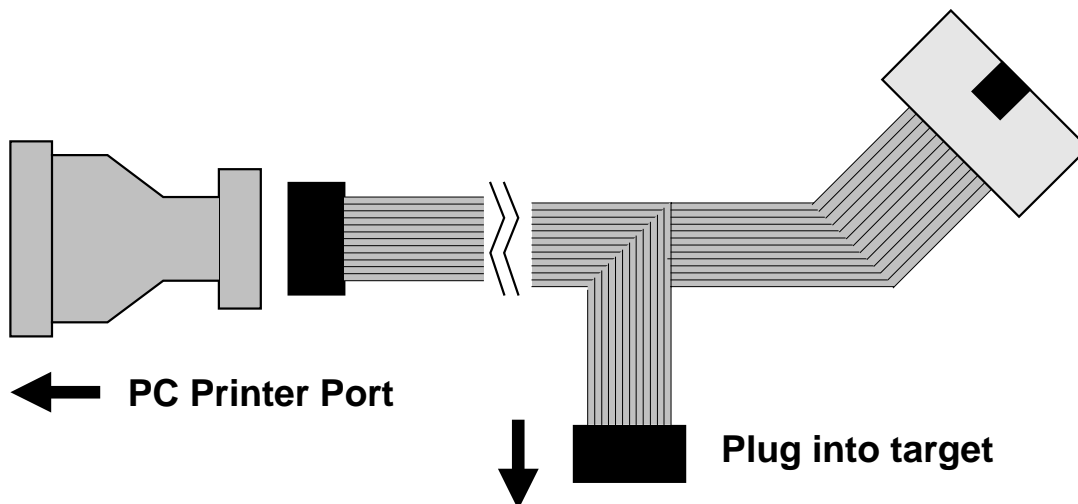

USING STK200 AND 300 with HAND HELD PROGRAMMER

1) STK200's and STK300's have two supply rails. Vcc and +5V. Vcc is the supply to the AVR microcontroller, while pin2 of the ISP connection is connected to the +5V rail. A result of this, is that the programmer can not be used to power the these boards during programming. They must be powered independently.

2) The original design of the STK300 reset circuit does not comply with the requirements of the programmer.

To allow programming of older STK300's, a small modification to the STK300 is required.



Check the value of the resistor indicated. If the value is 1K, it should be removed. STK200's requires no modification.

SAVING SETTINGS

The settings you have used can be saved for use again, in a FOB (.fob) file.

To save settings, click on **Save Fob button** on last page, and give the file a name.

To load a FOB settings file, click on **Browse button** on first screen and select the FOB file to load.

Note:

If you try and change device with a FOB file loaded, you may get unpredictable results. We advice you to NOT load a FOB file if you intend to change device as the fuses could be very different.

BATTERY AND POWER SUPPLY

The Handheld Programmer uses a standard 9V PP3 battery. These are commonly available.

The Handheld Programmer can also be powered from an external Power Supply. The power supply should be

- 2.1mm barrel connector (coaxial plug), centre positive.
- 9V DC regulated
- 300 mA plus

A universal PSU or Wall Transformer is available on the Kanda shop –
Order Code PSU9V-UNI

TROUBLESHOOTING

Error message: “Dongle was not detected – check connections and parallel port settings”

- 1) Ensure dongle (PC adapter) is connected to printer port
- 2) Check port setting – LPT1, LPT2 etc.
- 3) In BIOS, make sure port is set to EPP v1.9 or ECP
- 4) Some early versions of XP poll printer port – if you have early XP version, load service packs

Error Message: “Programmer is not responding – check connections and battery power”

- 1) Check that programmer is connected to PC as shown on Page 1
- 2) Check battery or power supply to the programmer

Programming Errors – RED Flashes on LED when programming

- 1) Ensure your target circuit is wired correctly as shown in connection diagram on Page 4
 - 2) Check power options are correct – see Power Options on Page 3
 - 3) Slow down programmer speed in software – especially if you have capacitors on programming lines or other unusual circuitry.
-

FURTHER INFORMATION

Please contact support@kanda.com for technical support or go to our website support pages for latest software.

See www.kanda.com/support

Contact details

Website: www.kanda.com

email: sales@kanda.com

Phone/Fax: +44 (0)8707 446 807



Atmel, AVR and associated logos are registered trade marks of Atmel Corp. San Jose, CA, USA