

- Portable
- Compact
- One button operation
- Comprehensive device support
- Field or production use
- 5V operation
- High and Low Voltage Programming
- Programmer includes 12V Generator HVP

**Device Support:**

All PIC18F Devices but total memory available is 128KB.

PIC16F devices - see page 3

Note  
Programmer powers target at 5V. Target can be powered as well to increase battery life

Order Code  
PIC-HH0010

For  **MICROCHIP**  
PICMicro®

# PIC Handheld Programmer

A portable ISP in a Handheld package



## Introduction

The ultimate programming tool for PIC microcontrollers, in the field or on the production line - so easy a child can use it! Just load it once and then program target devices again and again and again.

## One Starter Kit = Many Programmers

You require just one starter kit for your PC and you can load as many programmers as you need. Just connect the starter kit dongle to your printer port and run the master software. Select your code file, device type and settings and now you can load the programmers with your program or test code in seconds. As the programmer is battery powered during load, you don't need any power supplies or cabling, just plug a programmer into the lead supplied. Once a programmer is loaded, it is completely portable and can be used where you need it, not where your PC is located.

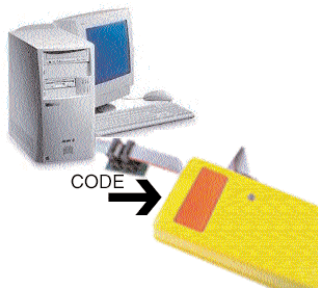

LOAD

MOVE

## Field Updates

Think how often you need a simple upgrade to a vending machine, slot machine or other equipment such as lifts, security controls or medical equipment - simple, except it is hundreds of miles away. The rugged design and simple operation of this unique programmer means that you can "let the Programmer do the walking" by sending the Keyfob rather than an expensive engineer.



PROGRAM

## Production line

Wouldn't it be nice to have a simple to use, completely portable yet low cost programmer, which can be loaded with different program code or test vectors, available where required on the production floor? Not possible? It is now, with the Handheld programmer - one button operation, auto sensing of target, auto verification and error indicator - that's really simple to use. Target circuit does not need to be powered, and low voltage targets are supported as programmer powers target.

The hand held programmer eliminates operator errors.

*Microchip, PICMicro and Microchip logo are the registered trade marks of Microchip Corp, Arizona, USA*

### Starter Kit Contents:

- One programmer with battery included.
- One Parallel port loader and lead.
- Programmer includes 12V Generator HVP
- PC software for Keyfob loading

Compatible with Windows 95/98/2000/NT/ME/XP

### Device Support:

All PIC18F Devices but total memory available is 128KB.

PIC16F devices - see page 3

### Note

Programmer powers target at 5V. Target can be powered as well to increase battery life

### Target Voltages

The Handheld programmer includes a 9V PP3 battery that is used for loading from the PC and powering your target circuit. The PIC handheld programmer is set to program target microcontrollers at 5V, regardless of the target circuit voltage. This is because of limitations with the PIC microcontroller below 4.5V as the Bulk Erase command does not work. So the programmer is set to power the target at 5V, therefore target circuits must be able to cope with 5V.

### Device Support

You need flexibility when it comes to choosing a device so we have made sure that the handheld programmer supports as many devices as possible.

- Most PIC18F and PIC16F devices are supported - see [www.kanda.com/support](http://www.kanda.com/support) for latest list
- Maximum code size is 128 Kbytes plus EEPROM
- If device has Programming Voltage 1st method of entering Programming mode, this is used in preference to Vdd first method
- Automatically loads and verifies the Code memory, data EEPROM, User ID, configuration bytes and write protection bits, if required

### Starter Kit Contents

- Hand Held Programmer
- PC Interface (Printer port)
- Ribbon cables- 10-way connectors
- Adapter for loading programmer
- Software CD
- Supplied in video case



### Starter Kit Software Features

- Supports Windows 95/98/2000/NT/ME/XP
- Simple software
- Drop-down device selection list
- Easy file selection
- Supports fuse data embedded in file only
- Program Flash, EEPROM, configuration data
- Select High or Low Voltage programming mode
- Match device ID option
- Verify configuration words option
- Program User ID information choice
- ClickUpload to load your programmer

### Programmer details

- Programmer Size 106 x 58 x 25mm
- Programmer Size 4.5 x 2.5 x 1 inch
- 9V PP3 battery included
- 9V 2.5mm barrel connector for PSU
- Programming voltage 5V
- 10-way to 6-way flexible adapter included



### Order Numbers

Product	Order Number
Starter kit including programmer	PIC-HH0010
Individual Programmer Only	PIC-HH0020

**YOU MUST HAVE A STARTER KIT TO LOAD THE INDIVIDUAL PROGRAMMERS**

Order Code  
PIC-HH0010

## Device Support:

All PIC18F Devices  
but total memory  
available is 128KB.

PIC16F devices  
Current Support -  
HVP + LVP:  
PIC16F87x

## Coming shortly:

HVP + LVP  
PIC16F627(A)  
PIC16F628(A)  
PIC16F648A  
PIC16F818  
PIC16F819  
PIC16F87  
PIC16F88  
PIC16F873A  
PIC16F874A  
PIC16F876A  
PIC16F877A

## HVP Only

PIC16F84A  
PIC16F83  
PIC16F84  
PIC16F684  
PIC16F716  
PIC16F5x  
PIC16F505  
PIC16F688  
PIC16F63x  
PIC16F68x  
PIC16F690  
PIC16F91x  
PIC16F630  
PIC16F676

Order Code  
PIC-HH0010

## Battery and Power Supply

### Battery Specification

SIZE: PP3  
TYPE: ALKALINE  
VOLTAGE: 9V

### Power Supply Specification

VOLTAGE: 9V  
Connector: 2.1mm barrel  
Polarity: Centre positive  
Current: 300 mA plus

## Current Consumption

### 1) Loading Programmer from PC

Programmer during firmware download : 20mA  
Programmer in idle mode (connected to PC) : 15mA  
Programmer during code and data loading : 25-35mA

**Do NOT leave programmer attached to PC for long periods as this will flatten battery.**

### 2) Target Programming

The programmer will power target at 5V with a **150 mA current limit**. The target does not need to be powered unless it requires more than 150 mA. Obviously, powering the target (even at lower voltages) will increase battery life. However, Vpp first method of entering Program Mode will not work if target is already powered

Alternatively, use a power supply for the programmer and you do not need to power target.

## Connectors

The 10-way pin-out of the programmer is shown here. A 10-way to 6-way flying lead adapter is supplied for flexibility

### 10-way Programmer output

#### End of lead view

Data - PGD	9	10	GND
Clock - PGC	7	8	GND
MCLR/Vpp	5	6	GND
PGM	3	4	GND
N/C	1	2	VDD

#### 6-way flying leads

Brown	—	GND
Red	—	MCLR/Vpp
Orange	—	PGM/LVP
Yellow	—	Clk PGC
Green	—	VDD
Blue	—	Data PGD

For Low Voltage programming, connect Orange PGM/LVP line  
For High Voltage Programming, this line can be left disconnected.

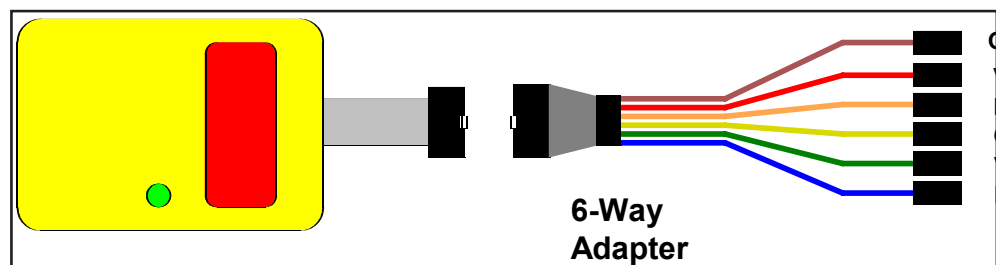

- Portable
- Compact
- One button operation
- Comprehensive device support
- Field or production use
- 5V operation
- High and Low Voltage Programming
- Programmer includes 12V Generator HVP

**Device Support:**

All PIC18F Devices but total memory available is 128KB.

PIC16F devices - see page 3

Note  
Programmer powers target at 5V. Target can be powered as well to increase battery life. However this will affect HVP programming with Vpp first method.

**Programming Modes**

The programmer supports both Low Voltage Programming (LVP) and High Voltage Programming (HVP) modes. You can select which mode you require during programmer loading from the PC.

As the programmer supplies 5V, and 12V HVP if required, to your target circuit, other devices in circuit must be 5V tolerant or protected. Please ensure that your application does not affect Data, Clock and MCLR lines by using serial resistors or other method.

**High Voltage Programming - HVP**

HVP mode used is Programming Voltage (Vpp) first i.e. before target voltage (Vdd) if this is available as this method is not code dependent. The programmer includes the 12V generator for HVP, so no external supply is needed.

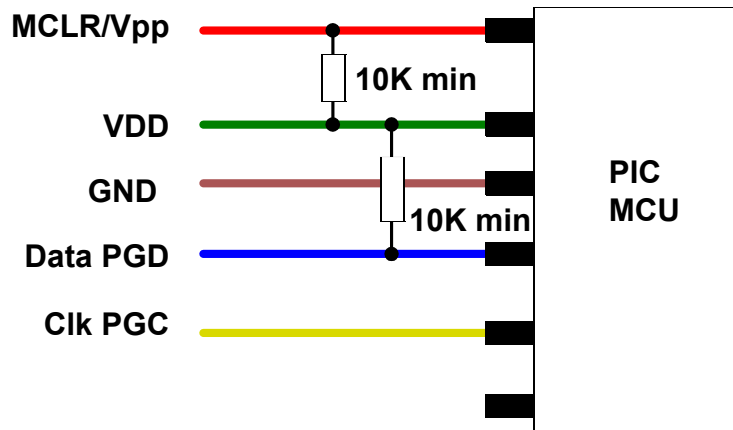

**12V High Voltage Programming Mode**

The resistor shown on Data line is optional, and can be up to 100K.

The resistor on MCLR/Vpp line must be included and should be in the range of 10K to 100K.

**Low Voltage Programming - LVP**

For LVP mode, connect the PGM/LVP line. Ensure Low voltage ICSP select bit is set during keyfob load.

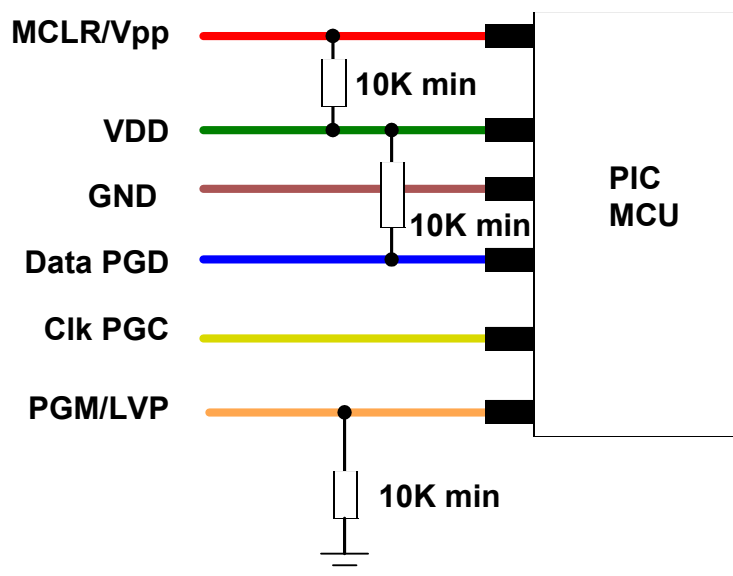

**5V Low Voltage Programming Mode**

The resistor shown on Data line is optional, and can be up to 100K.

The resistor on MCLR/Vpp line must be included and should be in the range of 10K to 100K.

The pull-down resistor on PGM/LVP pin is required, and should be in the range of 10K to 100K

**Embedded Results Ltd**  
P.O. Box 200  
Aberystwyth,  
SY23 2WD UK

**Tel: +44 (0) 8707 446 807**  
**Fax: +44 (0) 8707 446 807**  
**Email: sales@kanda.com**  
**Web: www.kanda.com**