

# ***DNP/SK21*** ***Embedded Linux Starter Kit***

## **First Steps**

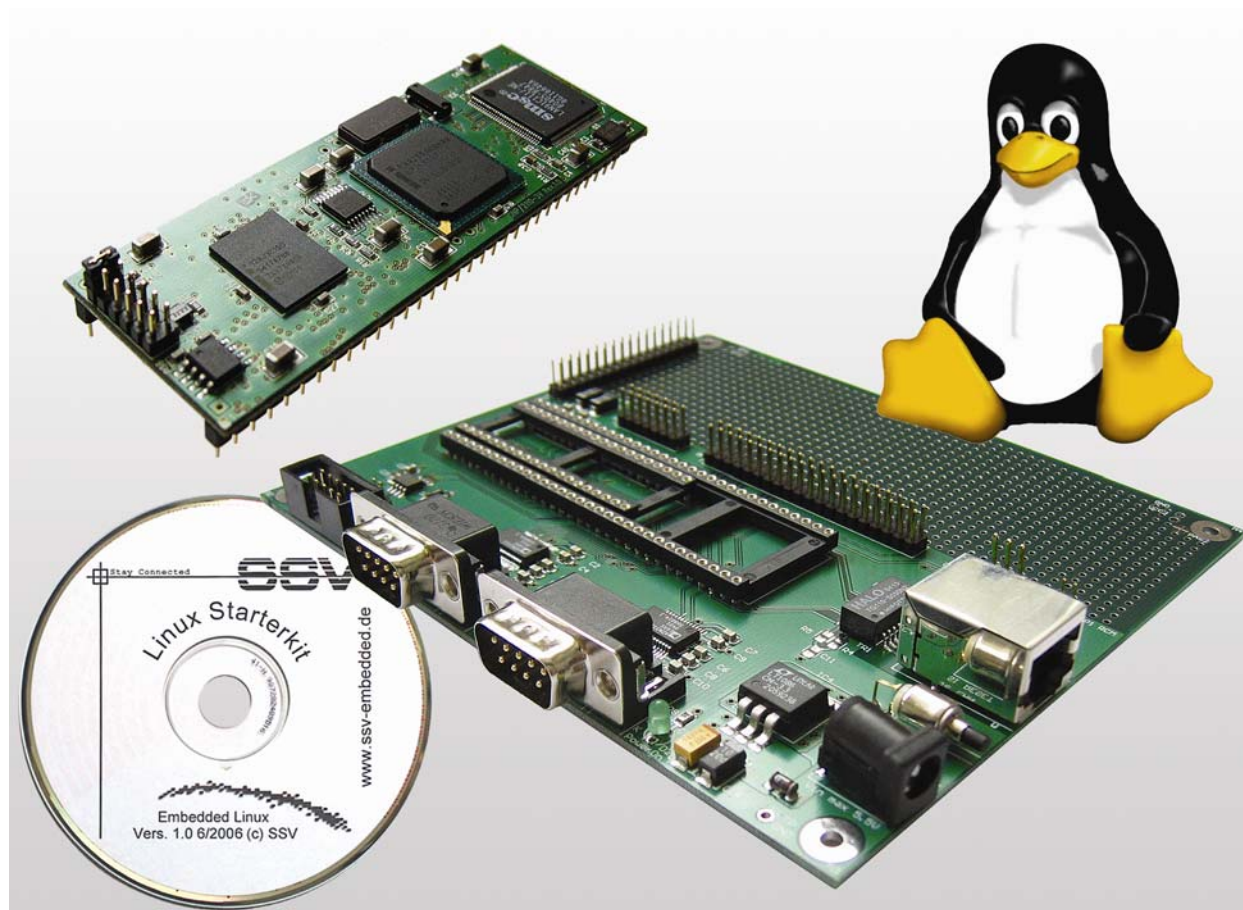

### **SSV Embedded Systems**

Heisterbergallee 72

D-30453 Hannover

Phone: +49 (0)511/40 000-0

Fax: +49 (0)511/40 000-40

E-mail: [sales@ist1.de](mailto:sales@ist1.de)

Manual Revision: 1.1

Date: 2005-12-20

# CONTENT

---

1	INTRODUCTION.....	3
1.1	Features and Technical Data.....	4
2	GETTING STARTED.....	5
2.1	Serial Link between DNP/EVA6-SV2 and PC.....	5
2.2	Ethernet Link between DNP/EVA6-SV2 and PC.....	6
2.3	Connecting Power Supply and Power-up the Starter Kit.....	7
2.4	Using Serial Link with Terminal Program.....	8
2.5	Power-up DNP/2110 without RCM Jumper (RCM disabled).....	9
2.6	Power-up DNP/2110 with RCM Jumper (RCM enabled).....	10
2.7	Checking IP Address of PC.....	11
2.8	Checking Ethernet-based TCP/IP Communication.....	12
2.9	Using a Telnet Connection.....	13
2.10	Checking DNP/2110 Embedded Web Server.....	14
2.11	Checking DNP/2110 FTP Server.....	16
2.12	Changing DNP/2110 Ex Factory IP Address (ipaddree usage).....	18
3	U-BOOT BOOT LOADER COMMAND OVERVIEW.....	20
	HELPFUL LITERATURE.....	21
	CONTACT.....	21
	DOCUMENT HISTORY.....	21
	COPYRIGHT.....	21

# 1 INTRODUCTION

---

The DIL/NetPC DNP/2110 Starter Kit contains everything you need to get started with your Intel PXA255 Xscale-based embedded networking application. The Starter Kit includes a DNP/2110 module with a pre-installed U-Boot boot loader and an embedded Linux, the Evaluation Board DNP/EVA6-SV2, power supply, serial interface (null modem) cable, a CD-ROM with software and documentation and a printed user manual for the first steps with the Starter Kit.

The Starter Kit CD-ROM comes with a full GNU cross tool chain for C/C++ software development. The binary files of this pre-build tool chain run on an x86 Linux-based host (SuSE, Red Hat or other) and builds executable files for the Intel PXA255 Xscale 32-bit RISC microcontroller.

For using the DNP/2110 Embedded Linux Starter Kit you need a development system. The minimal configuration for this system is a Windows-based PC with the HyperTerminal terminal emulation program and a free COM port (COM1, COM2 or USB-based COMx) for the RS232 serial link between the DNP/2110 and HyperTerminal.

For using the Ethernet link, your PC needs an Ethernet adapter with 10 Mbps or 10/100 Mbps LAN interface. This environment allows web server programming (HTML pages, Java Applets) and Linux shell script programming. For using the GNU C/C++ cross tool chain, it is necessary to run Linux on the development system.

## 1.1 Features and Technical Data

---

The DNP/2110 comes with a pre-installed U-Boot boot loader and an embedded Linux operating system. The DNP/2110 Linux consists of two main components: 1. the Linux kernel and 2. the root file system.

The DNP/2110 U-Boot boot loader allows downloading new Linux kernel versions and root file systems to the DNP/2110 RAM and Flash. This in-system programming feature can be used by a simple serial and Ethernet link between the development system and the DNP/2110.

- DIL/NetPC DNP/2110 with Intel 400 MHz PXA255, 16 Mbytes Flash and 16 Mbytes SDRAM, 3.3 VDC Vcc
- U-Boot boot loader and embedded Linux pre-installed in Flash memory
- Evaluation Board DNP/EVA6-SV2 (special version)
- Null modem cable
- 110 VAC or 230 VAC to 5 VDC international power supply
- CD-ROM with user manual and hardware/programmers manuals
- Embedded Linux with source
- GNU cross tool chain for C/C++ software development for Linux-based PCs
- GNU gdb and gdbserver for Ethernet-based remote debugging
- Linux remote login with Telnet
- Web server setup sample
- FTP server setup sample
- Many source code samples

## 2 GETTING STARTED

### 2.1 Serial Link between DNP/EVA6-SV2 and PC

Setup the serial link between the Evaluation Board DNP/EVA6-SV2 and your PC. Use a null modem cable for this connection.

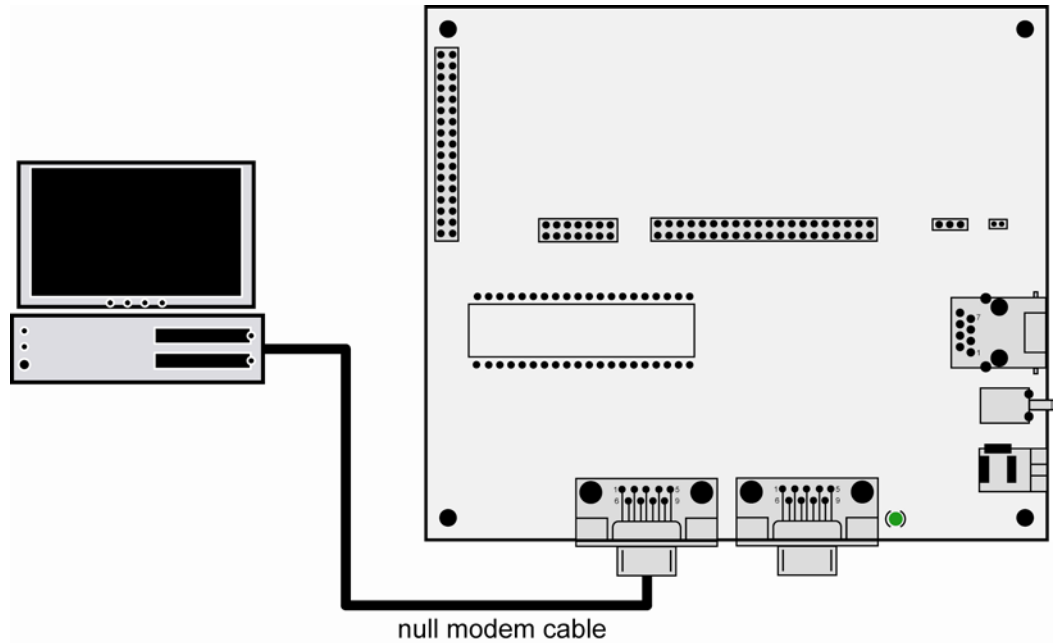
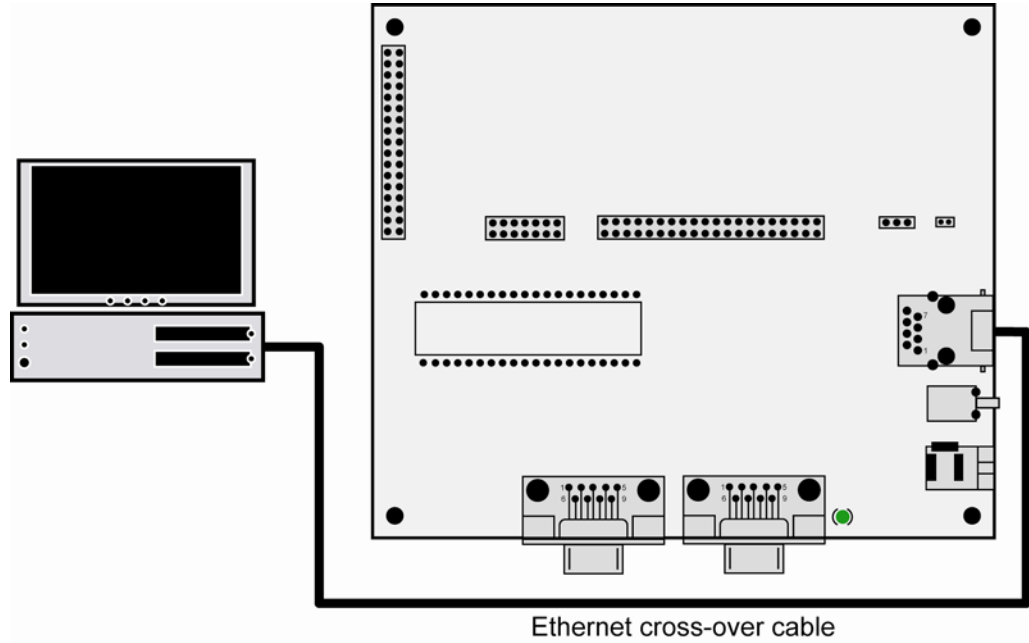

**Figure 1: Serial link between Evaluation Board and PC**

Connect one end of the null modem cable with an unused COM port of your PC. Make sure that this PC COM port supports 115.200 bps.

## 2.2 Ethernet Link between DNP/EVA6-SV2 and PC

Setup the Ethernet LAN link between the Evaluation Board DNP/EVA6-SV2 and your PC. Use an Ethernet cross-over cable or a switch-based infrastructure for the first LAN connection.



**Figure 2: Ethernet link between Evaluation Board and PC**

**Please note:** The DNP/2110 comes with the default IP address 192.168.0.126. Please make sure that your PC can work with the IP address range 192.168.0.x.

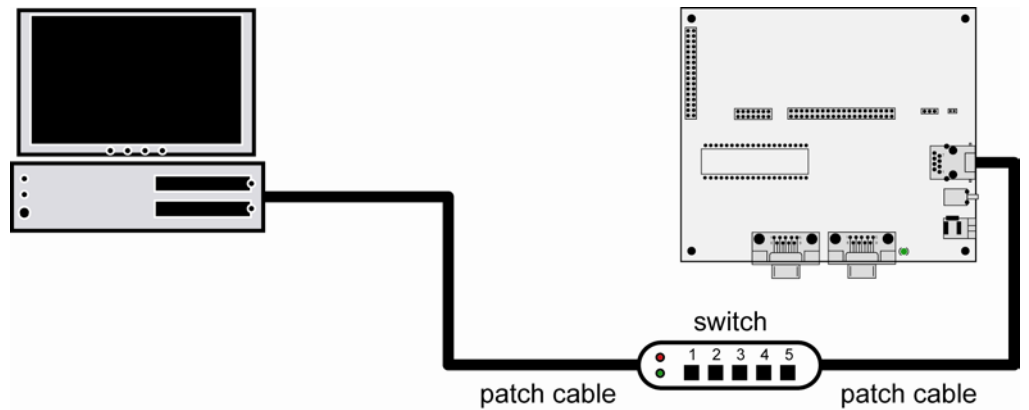

**Figure 3: Switch-based Ethernet link between Evaluation Board and PC**

## 2.3 Connecting Power Supply and Power-up the Starter Kit

Connect a 5 VDC power supply with a 5.5 mm x 2.5 mm jack plug to the Evaluation Board DNP/EVA6-SV2.

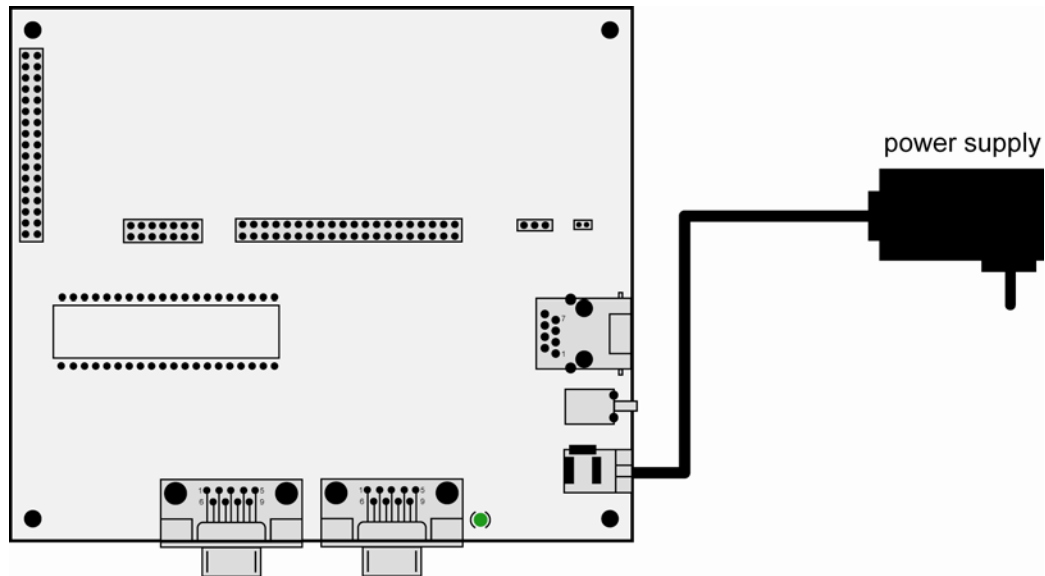

**Figure 4: Power supply for the Evaluation Board**

Please pay attention to the polarity of the power connector: the **+** pole is in the center!

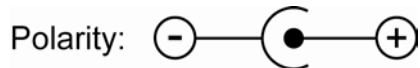

**Figure 5: Polarity of the power connector**

**Please note:** Make sure that all cable connections are OK. Then power-up the Starter Kit.

## 2.4 Using Serial Link with Terminal Program

Run *HyperTerminal* on your Windows-PC, *minicom* or a similar simple terminal emulation program on your Linux-based PC.



**Figure 6: Direct connection setup with HyperTerminal**

Setup a direct connection with the parameters of table 1. Make sure, that the PC COM port supports 115.200 bps.

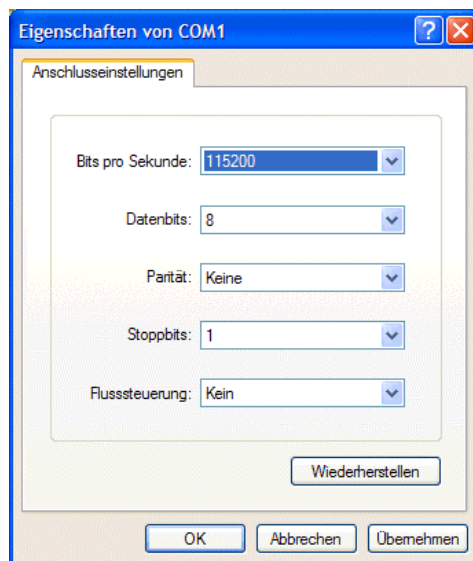

**Figure 7: Parameter setup with HyperTerminal**

Parameter	Value
Speed	115.200 bps
Data Bits	8
Parity	None
Stop Bits	1
Protocol	No (Xon/Xoff, RTS/CTS or similar)

**Table 1: Setup parameters for the serial link**

## 2.5 Power-up DNP/2110 without RCM Jumper (RCM disabled)

After power-up the DIL/NetPC DNP/2110 starts an automatic boot process from the on-board flash memory chip. This process consists of two steps:

1. Directly after power-up, the DNP/2110 runs the U-Boot boot loader program for some milliseconds. U-Boot initializes the hardware components (hardware init). **With RCM disabled** (please see the *DIL/NetPC DNP/2110 hardware reference manual* for details), there is no U-Boot text message output over the DNP/2110 COM1 serial interface and no **boot delay**-based<sup>1</sup> wait period. Direct after the hardware init, the U-Boot boot loader starts the Linux OS image.
2. Linux takes control over the DNP/2110 hardware and runs all necessary processes for coming up to live.

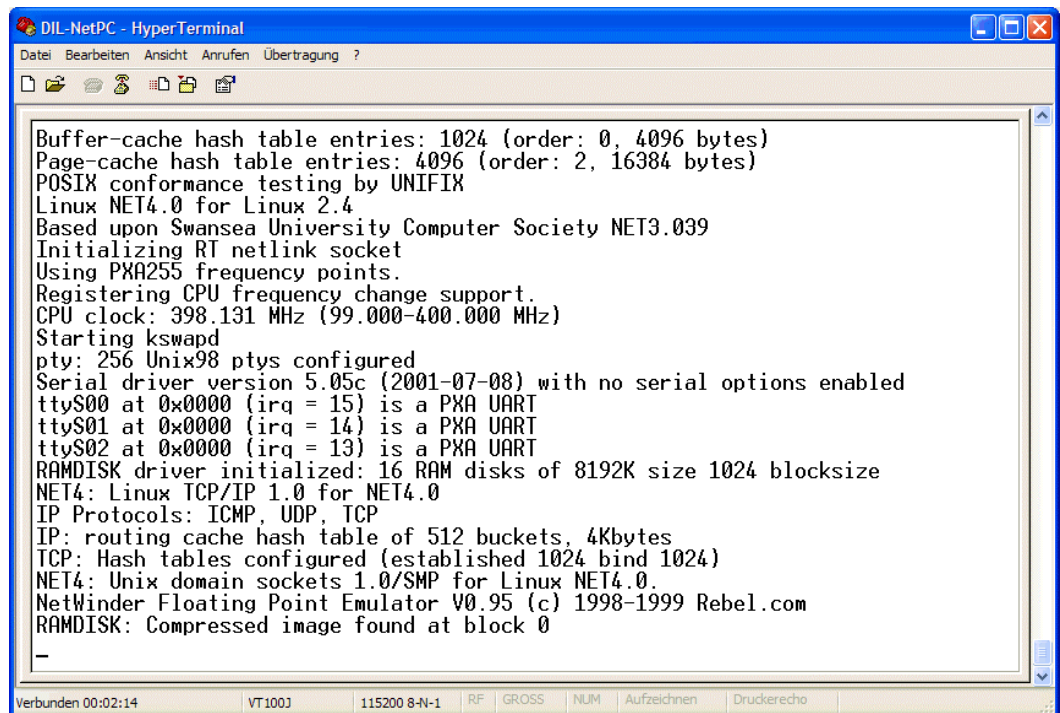

```

Buffer-cache hash table entries: 1024 (order: 0, 4096 bytes)
Page-cache hash table entries: 4096 (order: 2, 16384 bytes)
POSIX conformance testing by UNIFIX
Linux NET4.0 for Linux 2.4
Based upon Swansea University Computer Society NET3.039
Initializing RT netlink socket
Using PXA255 frequency points.
Registering CPU frequency change support.
CPU clock: 398.131 MHz (99.000-400.000 MHz)
Starting kswapd
pty: 256 Unix98 ptys configured
Serial driver version 5.05c (2001-07-08) with no serial options enabled
ttyS00 at 0x0000 (irq = 15) is a PXA UART
ttyS01 at 0x0000 (irq = 14) is a PXA UART
ttyS02 at 0x0000 (irq = 13) is a PXA UART
RAMDISK driver initialized: 16 RAM disks of 8192K size 1024 blocksize
NET4: Linux TCP/IP 1.0 for NET4.0
IP Protocols: ICMP, UDP, TCP
IP: routing cache hash table of 512 buckets, 4Kbytes
TCP: Hash tables configured (established 1024 bind 1024)
NET4: Unix domain sockets 1.0/SMP for Linux NET4.0.
NetWinder Floating Point Emulator V0.95 (c) 1998-1999 Rebel.com
RAMDISK: Compressed image found at block 0
-

```

**Figure 8: Linux booting process with HyperTerminal**

**Please note:** The U-Boot environment variable **boot delay** doesn't influence the DNP/2110 boot process with RCM (Remote Console Mode) disabled.

The DNP/2110 Linux supports a serial console. It allows running a Linux-based system in a headless configuration without a monitor or keyboard. Wait until the Linux boot process finishes. Then enter the user name **root**. This user name needs no password. Just hit Enter if the DNP/2110 Linux asks for a password.

<sup>1</sup> “**boot delay**” is a U-Boot environment variable. The value defines a wait time before U-Boot starts the Linux operating system.

## 2.6 Power-up DNP/2110 with RCM Jumper (RCM enabled)

The DIL/NetPC DNP/2110 boot sequence with RCM enabled is similar to the boot procedure with RCM disabled. Only the first step is different:

1. The DNP/2110 runs the U-Boot boot loader program. This software shows a wait message over the DNP/2110 COM1 serial interface if RCM is enabled (please see the *DIL/NetPC DNP/2110 hardware reference manual* for details). It is possible to interrupt the boot process and switch to the U-Boot command line interface. Just hit a key of your terminal emulation program.
2. Without interruption the U-Boot boot loader starts a Linux OS image after the wait period from the DNP/2110 Flash memory.

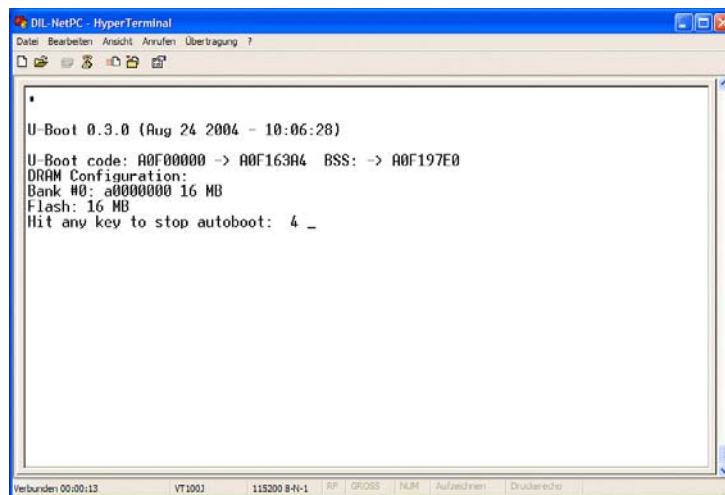

```

U-Boot 0.3.0 (Aug 24 2004 - 10:06:28)

U-Boot code: A0F00000 -> A0F163A4 BSS: -> A0F197E0
DRAM Configuration:
Bank #0: a0000000 16 MB
Flash: 16 MB
Hit any key to stop autoboot: 4 _

```

Figure 9: U-Boot wait message

**Please note:** The U-Boot command line interface allows you to change the wait time of the first step. Please see the U-Boot environment variable **boot delay** for details.

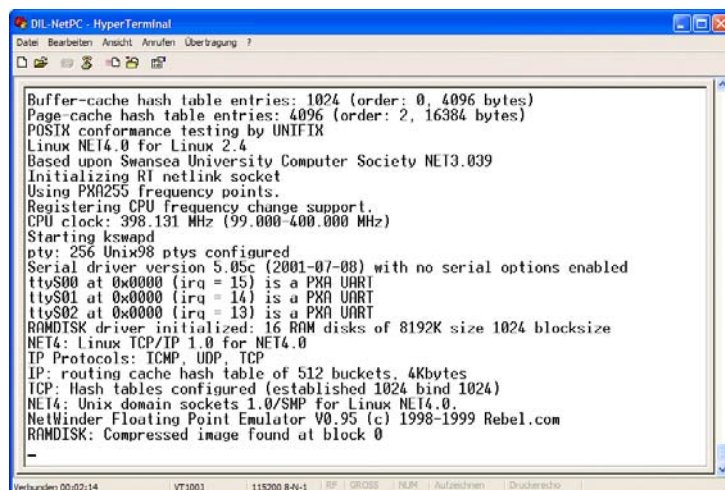

```

Buffer-cache hash table entries: 1024 (order: 0, 4096 bytes)
Page-cache hash table entries: 4096 (order: 2, 16384 bytes)
POSTIX conformance testing by UNIFIX
Linux NET4.0 for Linux 2.4
Based upon Swansea University Computer Society NET3.039
Initializing RI netlink socket
Using PXA255 frequency points.
Registering CPU frequency change support.
CPU clock: 398.131 MHz (99.000-400.000 MHz)
Starting kswapd
pty: 256 Unix98 ptys configured
Serial driver version 5.05c (2001-07-08) with no serial options enabled
ttyS00 at 0x0000 (irq = 15) is a PXA UART
ttyS01 at 0x0000 (irq = 14) is a PXA UART
ttyS02 at 0x0000 (irq = 13) is a PXA UART
RAWDISK driver initialized: 16 RAM disks of 8192K size 1024 blocksize
NET4: Linux TCP/IP 1.0 for NET4.0
IP Protocols: ICMP, UDP, TCP
IP: routing cache hash table of 512 buckets, 4Kbytes
TCP: Hash tables configured (established 1024 bind 1024)
NET4: Unix domain sockets 1.0/SMP for Linux NET4.0.
NetWinder Floating Point Emulator V0.95 (c) 1998-1999 Rebel.com
RAWDISK: Compressed image found at block 0
-

```

Figure 10: Linux booting process after the U-Boot boot delay

## 2.7 Checking IP Address of PC

Make sure that your PC is using the right IP address for the Ethernet-based TCP/IP communication with the DIL/NetPC. Use 192.168.0.1 or 192.168.0.254 for your PC and 192.168.0.126 for the DNP/2110.

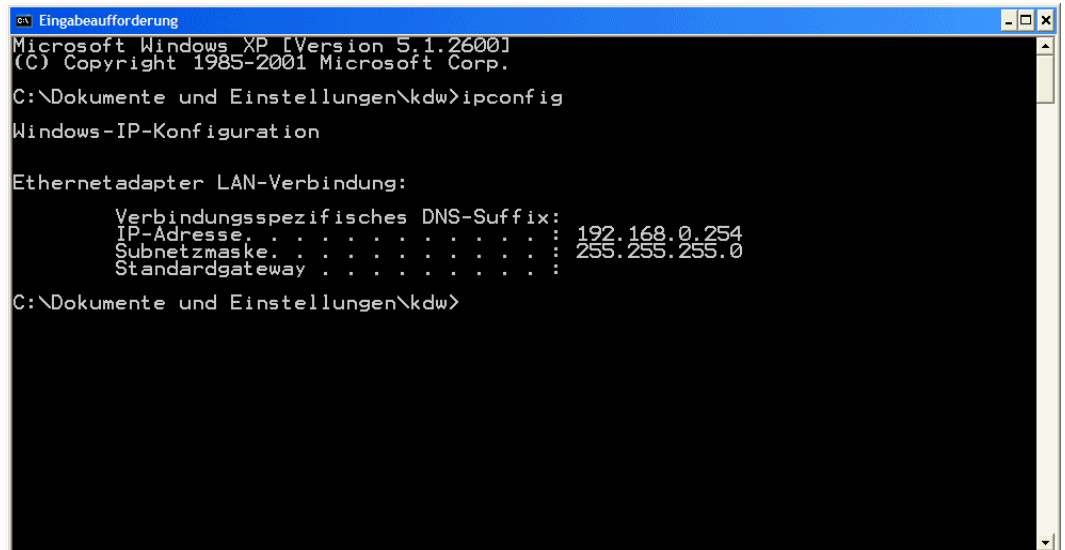

```
Microsoft Windows XP [Version 5.1.2600]
(C) Copyright 1985-2001 Microsoft Corp.

C:\Dokumente und Einstellungen\kdw>ipconfig

Windows-IP-Konfiguration

Ethernetadapter LAN-Verbindung:

    Verbindungsspezifisches DNS-Suffix:
    IP-Adresse. . . . . : 192.168.0.254
    Subnetzmaske. . . . . : 255.255.255.0
    Standardgateway . . . . . :

C:\Dokumente und Einstellungen\kdw>
```

**Figure 11: Windows-PC IP address check with *ipconfig***

Talk to your network administrator if you have problems with the IP address understanding.

## 2.8 Checking Ethernet-based TCP/IP Communication

Check the Ethernet-based TCP/IP communication between the DNP/2110 and the PC with a simple *ping* command.

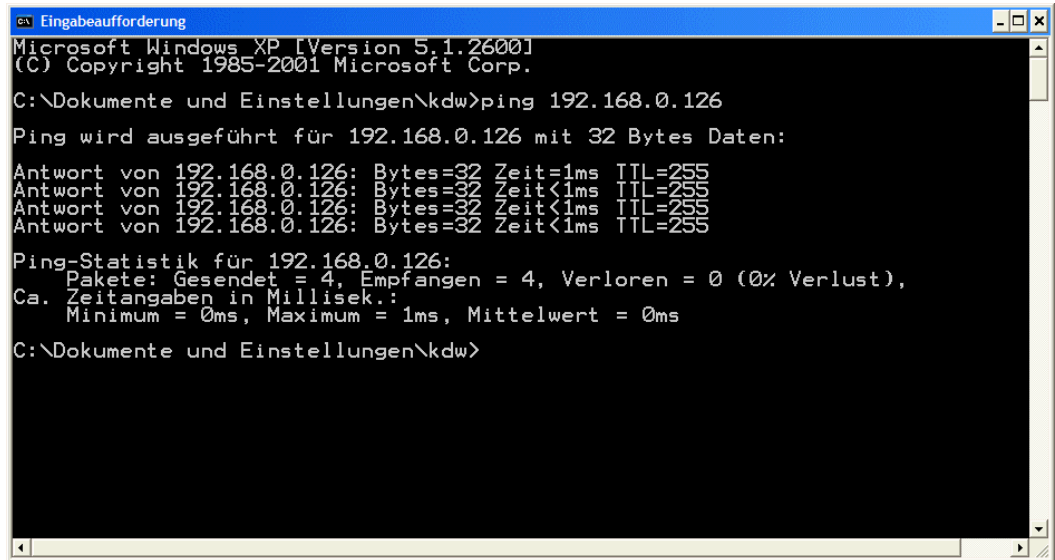

```
Eingabeaufforderung
Microsoft Windows XP [Version 5.1.2600]
(C) Copyright 1985-2001 Microsoft Corp.

C:\Dokumente und Einstellungen\kdw>ping 192.168.0.126

Ping wird ausgeführt für 192.168.0.126 mit 32 Bytes Daten:

Antwort von 192.168.0.126: Bytes=32 Zeit=1ms TTL=255
Antwort von 192.168.0.126: Bytes=32 Zeit<1ms TTL=255
Antwort von 192.168.0.126: Bytes=32 Zeit<1ms TTL=255
Antwort von 192.168.0.126: Bytes=32 Zeit<1ms TTL=255

Ping-Statistik für 192.168.0.126:
    Pakete: Gesendet = 4, Empfangen = 4, Verloren = 0 (0% Verlust),
    Ca. Zeitangaben in Millisek.:
        Minimum = 0ms, Maximum = 1ms, Mittelwert = 0ms

C:\Dokumente und Einstellungen\kdw>
```

**Figure 12: Windows-PC TCP/IP communication check with *ping***

First check the cable connections and then the IP addresses if your ping doesn't work. Then check the TCP/IP setup of your PC.

## 2.9 Using a Telnet Connection

Run a Telnet client program on your PC with the IP address of the DNP/2110. You can use a Telnet session for remote entering Linux commands.

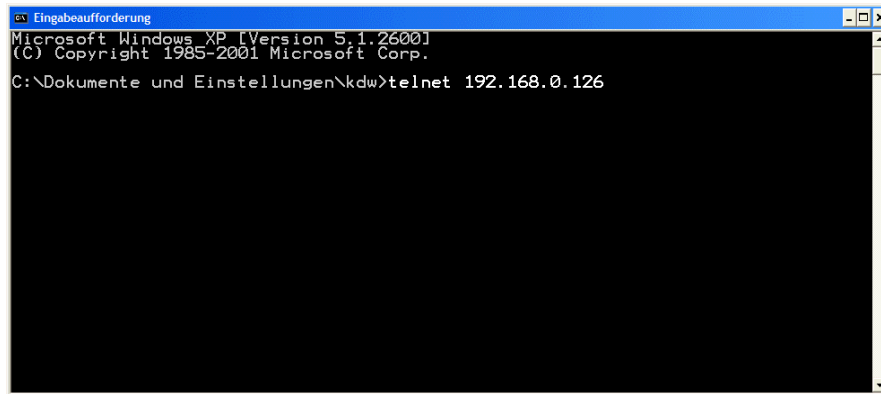

Figure 13: Run the Windows telnet client program

Wait until the DNP/2110 Linux requests a user name. Please enter the user name **root**. This user name needs no password. Just hit Enter if the DNP/2110 Linux requests a password.

**Please note:** The DNP/2110 Linux comes with *BusyBox*. All Linux command line commands are implemented in *BusyBox*. *BusyBox* combines tiny versions of many common UNIX utilities into a single small executable. It provides replacements for most of the utilities you usually find in GNU *fileutils*, *shellutils*, etc. The utilities in *BusyBox* generally have fewer options than their full-featured GNU cousins; however, the options that are included provide the expected functionality and behave very much like their GNU counterparts. *BusyBox* provides a fairly complete environment for any small or embedded system.

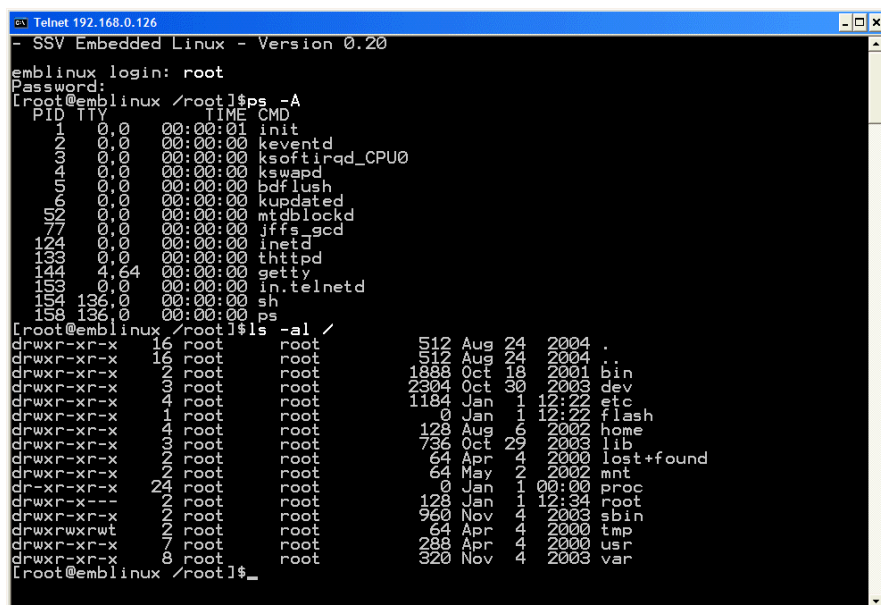

Figure 14: Using Linux commands within a Telnet client window

## 2.10 Checking DNP/2110 Embedded Web Server

The DIL/NetPC DNP/2110 default Linux configuration comes with a pre-installed embedded web server. The object storage space (HTML pages, pictures, CGI programs, Java Applets, ...) for this web server is located within the DNP/2110 Flash memory.

Setup a Telnet session with root user rights from your PC to the DNP/2110 (see chapter 2.9 if necessary). Enter the following command lines within this Telnet session:

```
cd /flash
mkdir www
cd www
cat > test.html
<html>
<head>
<title>Hallo Welt!</title>
</head>
<body>
<h1>Hallo Welt!</h1>
</body>
</html>
CTRL-D (CTRL-D stops the Linux cat command)
```

These command lines create an HTML file `/flash/www/test.html` within the DNP/2110 Flash memory with the German version of “Hello World” (“Hallo Welt!”).

Reboot your DNP/2110. This reboot defines `/flash/www/` as default directory for the web server.

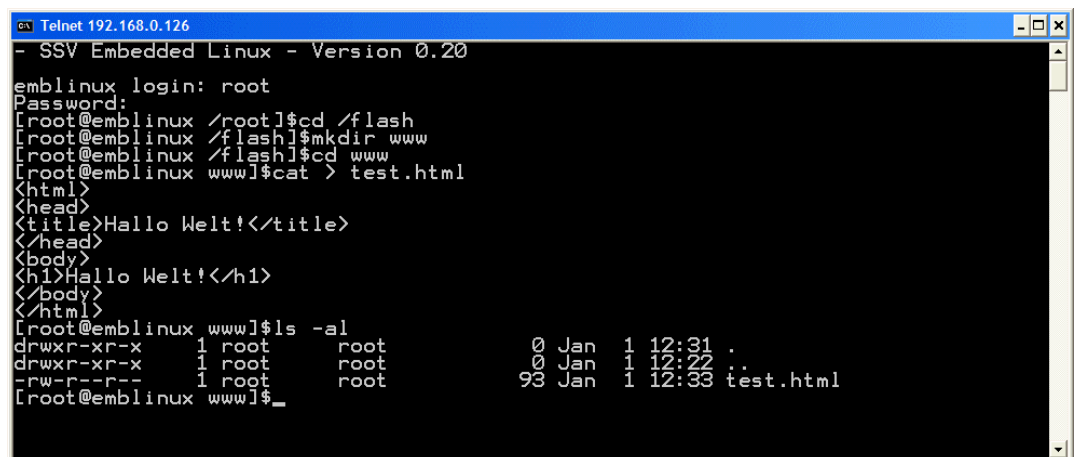

```

Telnet 192.168.0.126
- SSV Embedded Linux - Version 0.20
emblinux login: root
Password:
[root@emblinux /root]#cd /flash
[root@emblinux /flash]#mkdir www
[root@emblinux /flash]#cd www
[root@emblinux www]#cat > test.html
<html>
<head>
<title>Hallo Welt!</title>
</head>
<body>
<h1>Hallo Welt!</h1>
</body>
</html>
[root@emblinux www]#ls -al
drwxr-xr-x  1 root  root           0 Jan  1 12:31 .
drwxr-xr-x  1 root  root           0 Jan  1 12:22 ..
-rw-r--r--  1 root  root          93 Jan  1 12:33 test.html
[root@emblinux www]#_

```

**Figure 15: Create an HTML file within a Telnet session**

Run your PC web browser and access the HTML file `test.html` with your browser. Use the URL `http://192.168.0.126/test.html`. This URL assumes that your DNP/2110 is using the IP address 192.168.0.126 for the Ethernet LAN interface LAN1. Change this IP address if necessary.

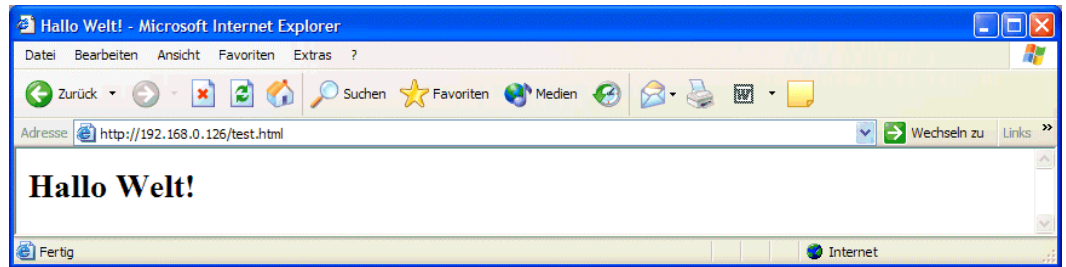

**Figure 16: Check the embedded web server with Internet Explorer**

**Please note:** `/flash/www` is the default directory for the DNP/2110 embedded web server. Restart the DNP/2110 Linux after the creation of `/flash/www/test.html` and before the first access with a web browser. The DNP/2110 embedded web server looks out for `/flash/www` at boot time. If the directory `/flash/www` does not exist at boot time, the DNP/2110 embedded web server works with the RAM disk-based directory `/usr/local/www`.

## 2.11 Checking DNP/2110 FTP Server

The DIL/NetPC DNP/2110 Linux comes with a pre-installed FTP server. This server allows the file transfer between a PC and the DNP/2110.

Run an FTP client program on your PC. Set the session parameters for your FTP client to IP address **192.168.0.126**, user name **guest** and password **guest**. The DNP/2110 default directory for the FTP user name guest is /home/guest. This directory is located within the DNP/2110 RAM disk.

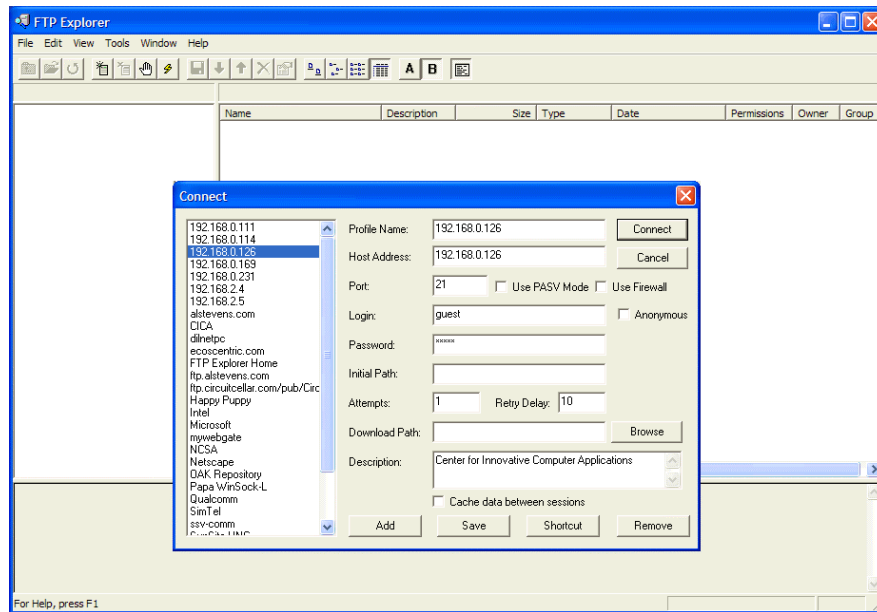

**Figure 17: Set the session parameters for an FTP client program**

Connect your FTP client with the DNP/2110 FTP server. Please watch the DNP/2110 default FTP directory. Transfer some files from your PC to the DNP/2110. The DNP/2110 stores these files in the DNP/2110 default FTP directory.

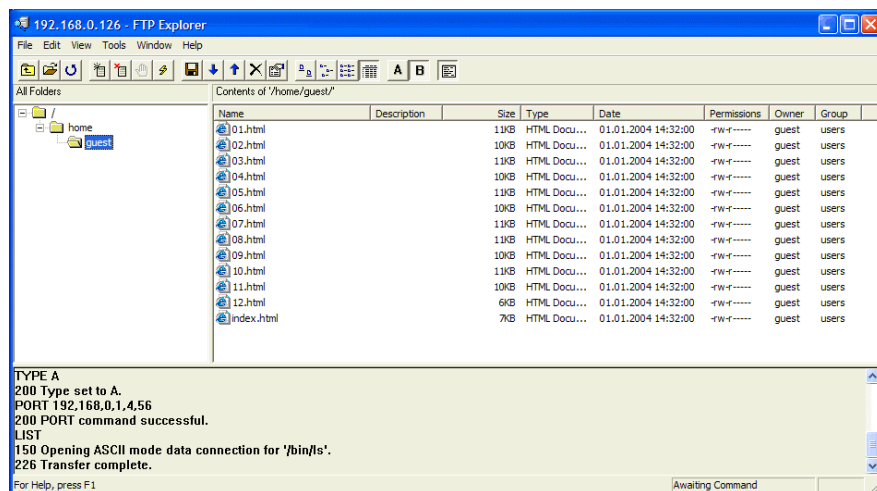

**Figure 18: Transfer some files to the DNP/2110**



## 2.12 Changing DNP/2110 Ex Factory IP Address (ipaddree usage)

Every device connected to an IP network must have a unique IP address. This address is used to reference the specific unit.

The DIL/NetPC DNP/2110 is automatically assigned an IP address on DHCP-enabled networks as it is DHCP-enabled by default. If DHCP doesn't work (i.e. no DHCP server available), the DNP/2110 takes a default IP address.

The ex factory value for this default IP address is **192.168.0.126**. The network mask for this address is **255.255.255.0**. You can change this IP address over an RS232-based serial link with help of the program called **ipaddree**.

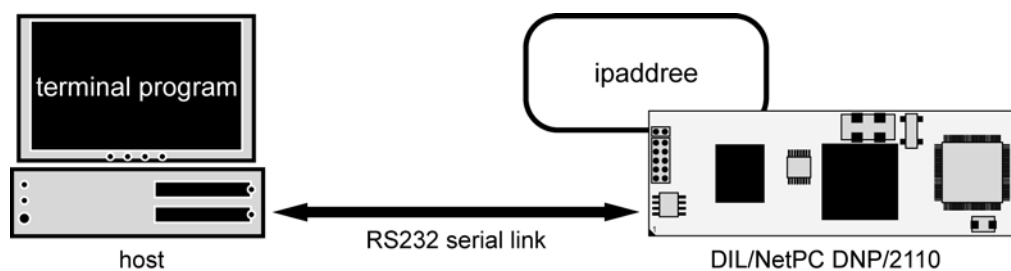
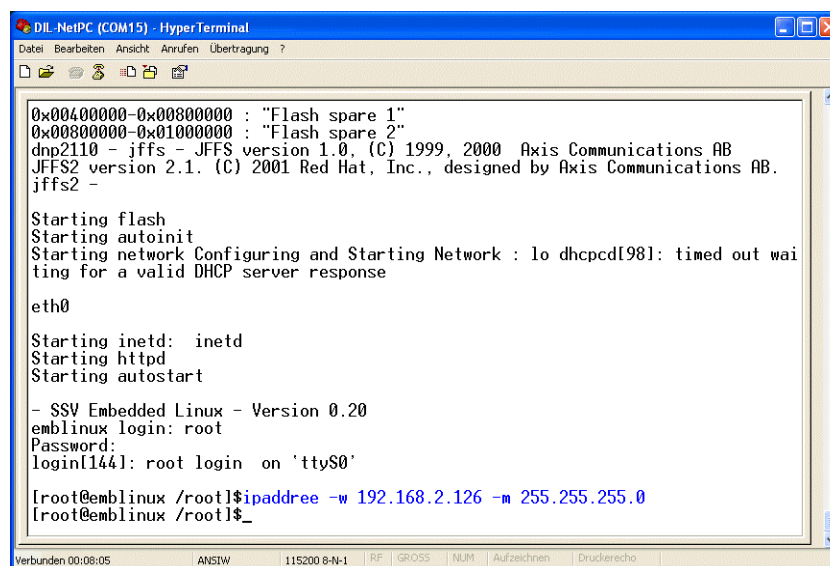

**Figure 20: Environment for ipaddree usage**

Use a serial console and enter the user name **root**. This user name needs no password. Just hit Enter if the DNP/2110 Linux requests a password. Then execute the following command:

```
ipaddree -w 192.168.2.126 -m 255.255.255.0
```

“ipaddree” is the name of a command line IP setup tool. “192.168.2.126” is an IP address. Use the IP address of your choice for your setup on this position. “255.255.255.0” is a network mask. Use a valid network mask for your IP address.



```
DIL-NetPC (COM15) - HyperTerminal
Datei Bearbeiten Ansicht Anrufen Übertragung ?
0x00400000-0x00800000 : "Flash spare 1"
0x00800000-0x01000000 : "Flash spare 2"
dnp2110 - jffs - JFFS version 1.0. (C) 1999, 2000 Axis Communications AB
JFFS2 version 2.1. (C) 2001 Red Hat, Inc., designed by Axis Communications AB.
jffs2 -

Starting flash
Starting autoinit
Starting network Configuring and Starting Network : lo dhcpd[98]: timed out waiting for a valid DHCP server response

eth0

Starting inetd: inetd
Starting httpd
Starting autostart

- SSV Embedded Linux - Version 0.20
emlinux login: root
Password:
login[144]: root login on 'ttyS0'

[root@emlinux /root]$ipaddree -w 192.168.2.126 -m 255.255.255.0
[root@emlinux /root]$_

Verbunden 00:08:05 ANSIW 115200 8-N-1 RF GROSS NJM Aufzeichnen Druckerecho
```

**Figure 21: Serial console with ipaddree command line**

Reboot the DNP/2110. The new IP address and network mask are valid after the next boot process if no DHCP server is available or if DHCP doesn't work. Check the new IP address with *ping*.



```
C:\>ping 192.168.2.126
Ping wird ausgeführt für 192.168.2.126 mit 32 Bytes Daten:
Antwort von 192.168.2.126: Bytes=32 Zeit<1ms TTL=64
Antwort von 192.168.2.126: Bytes=32 Zeit<1ms TTL=64
Antwort von 192.168.2.126: Bytes=32 Zeit<1ms TTL=64
Antwort von 192.168.2.126: Bytes=32 Zeit<1ms TTL=64
Ping-Statistik für 192.168.2.126:
    Pakete: Gesendet = 4, Empfangen = 4, Verloren = 0 (0% Verlust),
    Ca. Zeitangaben in Millisek.:
        Minimum = 0ms, Maximum = 0ms, Mittelwert = 0ms
C:\>
```

**Figure 22:** Check the new IP address with *ping*

**Please note:** Don't forget to change the IP address of your PC to 192.168.2.1 or similar.

### 3 U-BOOT BOOT LOADER COMMAND OVERVIEW

The user interface to U-Boot consists of a command line interpreter (CLI), much like a Linux shell prompt. When connected via a serial line you can interactively enter commands and see the results. The following table shows the available U-Boot commands for the DIL/NetPC DNP/2110.

Command	Function
autoscr	run script from memory
base	print or set address offset
bdinfo	print Board Info structure
bootm	boot application image from memory
bootp	boot image via network using BootP/TFTP protocol
bootd	boot default, i.e., run 'bootcmd'
cmp	memory compare
cp	memory copy
crc32	checksum calculation
echo	echo args to console
erase	erase FLASH memory
flinfo	print FLASH memory information
go	start application at address 'addr'
help	print online help
iminfo	print header information for application image
loadb	load binary file over serial line (kermit mode)
loadc	load binary file over serial line (ymodem-c mode)
loadg	load binary file over serial line (ymodem-g mode)
loads	load S-Record file over serial line
loop	infinite loop on address range
md	memory display
mm	memory modify (auto-incrementing)
mtest	simple RAM test
mw	memory write (fill)
nm	memory modify (constant address)
printenv	print environment variables
protect	enable or disable FLASH write protection
rarpboot	boot image via network using RARP/TFTP protocol
reset	perform RESET of the CPU
run	run commands in an environment variable
saveenv	save environment variables to persistent storage
setenv	set environment variables
sleep	delay execution for some time
tftpboot	boot image via network using TFTP protocol and env variables ipaddr and serverip
version	print monitor version
?	alias for 'help'

**Table 2: U-Boot command overview**

## HELPFUL LITERATURE

---

Intel PXA255 Processor: developers manual (Intel order number 278693-001)  
Intel PXA255 Processor: data sheet (Intel order number 278780)  
Intel PXA255 Processor: users manual (Intel order number 278796)  
DIL/NetPC DNP/2110 hardware reference manual (SSV Starter Kit item)  
DNP/EVA6 hardware reference manual (SSV Starter Kit item)

## CONTACT

---

**Kanda.com**

P.O. Box 200, Aberystwyth  
SY23 2WD  
Phone: +44 (0)8707 446 807  
Fax: +44 (0)8707 446 807  
E-mail: sales@kanda.com  
Internet: www.kanda.com

## DOCUMENT HISTORY

---

Revision	Date	Remarks	Name
1.0	2005-12-19	first version	WBU
1.1	2005-12-20	small errors in chapter 1 corrected	WBU

## COPYRIGHT

---

The content of this document can change any time without announcement. There is taken over no guarantee for the accuracy of the statements. The user assumes the entire risk as to the accuracy and the use of this document. Information in this document is provided 'as is' without warranty of any kind.

Some names within this document can be trademarks of their respective holders.

© 2005 SSV EMBEDDED SYSTEMS. All rights reserved.