

For  MICROCHIP PICMicro®

# PIC Handheld Programmer

## A portable ISP in a Handheld package



The ultimate programming tool for PIC microcontrollers, in the field or on the production line - so easy a child can use it! Just load it once and then program target devices again and again and again.

### One Starter Kit = Many Programmers

You need one starter kit to load your Hand Held Programmer with settings and code from a PC or laptop, using the simple Wizard software and the USB port connector supplied in the starter kit.

Once your programmer is loaded, you can program as many target devices as you want. It is ideal for field or production use and it is impossible for inexperienced operators to make errors. One button operation and clear Red/Green LED error indicator prevents mistakes.

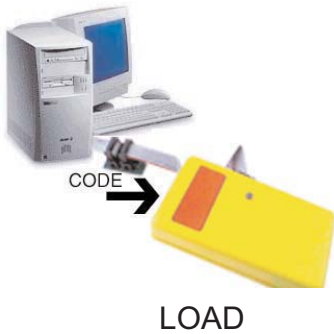

Just connect the starter kit to your USB port and run the wizard software. Select your program and/or EEPROM files, device type, fuse settings and device voltage in the simple Wizard screens and load your program or test code in seconds. As the programmer is battery powered during load, you don't need any power supplies or cabling, just plug a program-

mer into the simple adapter supplied with the starter kit.

Once a programmer is loaded, it is completely portable and can be used where you need it, not where your PC is located. The programmer will retain your code even if you remove the battery as it is stored in non-volatile memory.



MOVE

For field use, you can use the 9V PP3 battery included. It will even power your target circuit with up to 150mA.

Alternatively plug in a 9V power supply and save on battery life.

### Programming your targets

To use your programmer on the production line or in the field is so easy! Plug the programmer lead into the 10-way header on the target and press the big red button. During the program and verify operations, the LED flashes green. Once it is finished, a steady green light shows programming and verify was successful. If there were errors, the LED flashes red with a sequence that shows what error occurred: 1 flash = No response from device, 2 = Erase failed, 3 = Program failed, 4 = Fuse write failed. These codes will repeat if the stay on time is set in the software wizard timing screen.

The programmer can supply power to a target board, provided it doesn't draw more than 150mA which is great for field use or adding QA or configuration data in the PIC EEPROM at different work stations. Alternatively, the programmer can draw power from the target.



PROGRAM

#### Features

- Portable
- Compact
- One button operation
- 9V Battery or PSU
- Comprehensive device support
- Can power target
- Field use
- Production use
- Supports all fuses
- Supports Lock bits
- Supports 3-5V Vcc
- 256KB memory
- USB Version
- Program EEPROM only option
- Program Flash only option
- Program both Flash and EEPROM
- Automatic verify
- High and Low Voltage Programming
- Includes 12V generator

#### Device Support:

All PIC18F Devices but total memory available is 256KB. PIC16F devices - see page 3

#### Note

Programmer powers target at 5V (3.3V for J parts) Target can be powered as well to increase battery life

Order Code  
PIC-HH0010U

### Starter Kit Contents:

- One programmer with battery included.
- One USB port loader and lead.
- Programmer includes 12V Generator for HVP
- PC software for Programmer loading

### Device Support:

All PIC18F Devices but total memory available is 256KB.  
 PIC16F devices - see page 3  
 Note  
 Programmer powers target at 5V.  
 Target can be powered as well to increase battery life

### Operating Systems

- WIN 2000/ME
- WIN XP
- WIN VISTA

### Starter Kit Contents

- Hand Held Programmer
- PC Interface (USB port)
- Ribbon cables- 10-way connector
- 6 way flying leads
- Software CD
- Supplied in video case



### Software Features

- Supports Windows 2000/ME/XP/VISTA
- Simple software
- Drop-down device selection list
- Easy file selection
- Supports fuse data embedded in file only
- Program Flash, EEPROM, configuration data
- Select High or Low Voltage programming mode
- Match device ID option
- Verify configuration words option
- Program User ID information choice
- Click Upload to load your programmer

### Power Options

The Handheld programmer includes a 9V PP3 battery that is used for loading from the PC and powering your target circuit. The PIC handheld programmer is set to program target microcontrollers at 5V, regardless of the target circuit voltage. This is because of limitations with the PIC microcontroller below 4.5V as the Bulk Erase command does not work.

So the programmer is set to power the target at 5V, therefore target circuits must be able to cope with 5V, except for PIC18FxxJ devices, where supplied voltage is 3.3V.

### Device Support

You need flexibility when it comes to choosing a device so we have made sure that the handheld programmer supports as many devices as possible.

- Most PIC18F and PIC16F devices are supported - see [www.kanda.com/support](http://www.kanda.com/support) for latest list
- Maximum code size is 256 Kbytes including EEPROM
- If device has Programming Voltage 1st method of entering Programming mode, this is used in preference to Vdd first method
- Automatically loads and verifies the Code memory, data EEPROM, User ID, configuration bytes and write protection bits, if required

### Programmer Features

- Programmer Size 106 x 58 x 25mm
- Programmer Size 4.5 x 2.5 x 1 inch
- 9V PP3 battery included
- 9V 2.5mm barrel connector for PSU
- Flexible Vcc range - 0 to 5V
- 256 KB memory capacity for most PICs
- Non-volatile storage keeps your data
- Supports PIC16F and PIC18F devices
- Single button operation
- Red/Green error LED

Product	Order Number
Hand Held Programmer Starter kit - Parallel	PIC-HH0010
Hand Held Programmer Starter kit - USB	PIC-HH0010U
256KB Hand Held Programmer	PIC-HH0020
9V International Power Supply	PSU9V-UNI

**YOU MUST HAVE A STARTER KIT TO LOAD THE INDIVIDUAL PROGRAMMERS**

Order Code  
 PIC-HH0010U



## Device Support:

All PIC18F Devices  
but total memory  
available is 256KB.

PIC16F devices  
Current Support -  
HVP + LVP:

PIC16F87x

Coming shortly:

HVP + LVP

PIC16F627(A)

PIC16F628(A)

PIC16F648A

PIC16F818

PIC16F819

PIC16F87

PIC16F88

PIC16F873A

PIC16F874A

PIC16F876A

PIC16F877A

HVP Only

PIC16F84A

PIC16F83

PIC16F84

PIC16F684

PIC16F716

PIC16F5x

PIC16F505

PIC16F688

PIC16F63x

PIC16F68x

PIC16F690

PIC16F91x

PIC16F630

PIC16F676

## Battery and Power Supply

### Battery Specification

SIZE: PP3  
TYPE: ALKALINE  
VOLTAGE: 9V

### Power Supply Specification

VOLTAGE: 9V  
Connector: 2.1mm barrel  
Polarity: Centre positive  
Current: 300 mA plus

## Current Consumption

### 1) Loading Programmer from PC

Programmer during firmware download : 20mA  
Programmer in idle mode (connected to PC) : 15mA  
Programmer during code and data loading : 25-35mA

**Do NOT leave programmer attached to PC for long periods as this will flatten battery.**

### 2) Target Programming

The programmer will power target at 5V with a **150 mA current limit**. The target does not need to be powered unless it requires more than 150 mA. Obviously, powering the target (even at lower voltages) will increase battery life. However, Vpp first method of entering Program Mode will not work if target is already powered

Alternatively, use a power supply for the programmer and you do not need to power target.

## Connectors

The 10-way pin-out of the programmer is shown here. A 10-way to 6-way flying lead adapter is supplied for flexibility

### 10-way Programmer output

#### End of lead view

Data - PGD	9	10	GND
Clock - PGC	7	8	GND
MCLR/Vpp	5	6	GND
PGM	3	4	GND
N/C	1	2	VDD

#### 6-way flying leads

Brown	—	GND
Red	—	MCLR/Vpp
Orange	—	PGM/LVP
Yellow	—	Clk PGC
Green	—	VDD
Blue	—	Data PGD

For Low Voltage programming, connect Orange PGM/LVP line  
For High Voltage Programming, this line can be left disconnected.

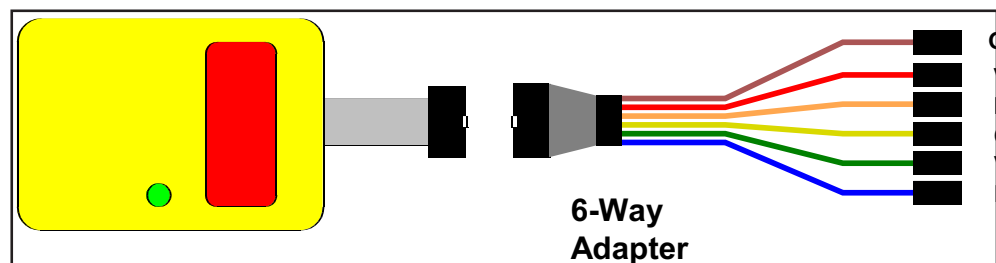

Order Code  
PIC-HH0010U

- Portable
- Compact
- One button operation
- Comprehensive device support
- Field or production use
- 5V operation
- High and Low Voltage Programming
- Programmer includes 12V Generator HVP

**Device Support:**

All PIC18F Devices but total memory available is 256KB.

PIC16F devices - see page 3

**Note**  
 Programmer powers target at 5V. Target can be powered as well to increase battery life. However this will affect HVP programming with Vpp first method.

**Programming Modes**

The programmer supports both Low Voltage Programming (LVP) and High Voltage Programming (HVP) modes. You can select which mode you require during programmer loading from the PC.

As the programmer supplies 5V, and 12V HVP if required, to your target circuit, other devices in circuit must be 5V tolerant or protected. Please ensure that your application does not affect Data, Clock and MCLR lines by using serial resistors or other method.

**High Voltage Programming - HVP**

HVP mode used is Programming Voltage (Vpp) first i.e. before target voltage (Vdd) if this is available as this method is not code dependent. The programmer includes the 12V generator for HVP, so no external supply is needed.

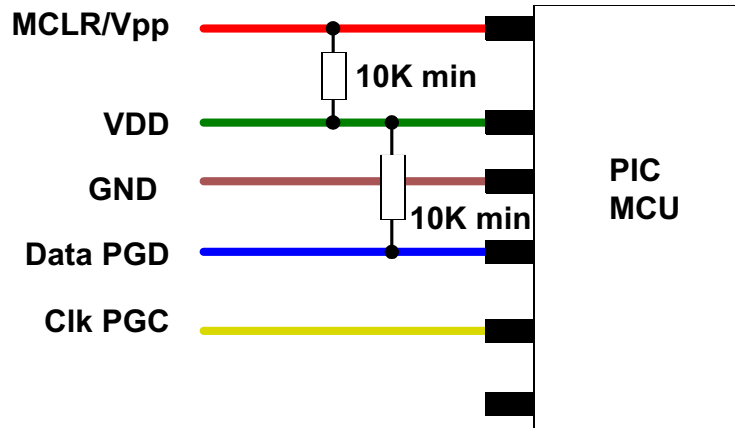

**12V High Voltage Programming Mode**

The resistor shown on Data line is optional, and can be up to 100K.

The resistor on MCLR/Vpp line must be included and should be in the range of 10K to 100K.

**Low Voltage Programming - LVP**

For LVP mode, connect the PGM/LVP line. Ensure Low voltage ICSP select bit is set during keyfob load.

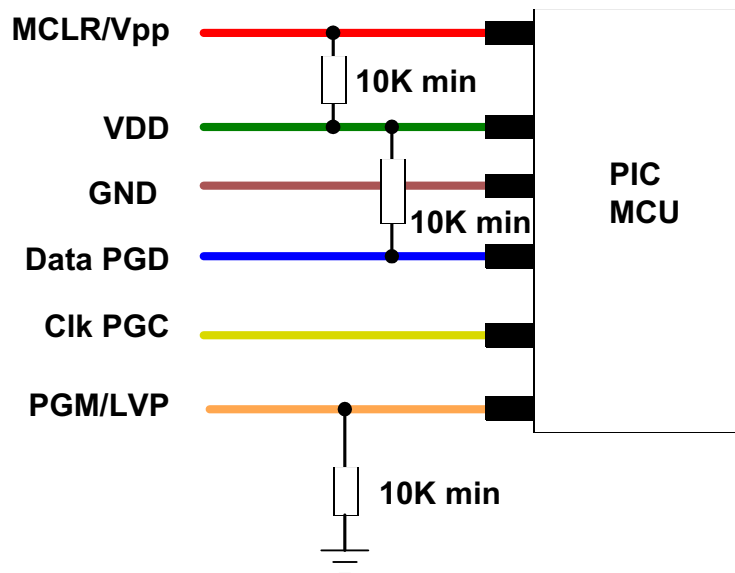

**5V Low Voltage Programming Mode**

The resistor shown on Data line is optional, and can be up to 100K.

The resistor on MCLR/Vpp line must be included and should be in the range of 10K to 100K.

The pull-down resistor on PGM/LVP pin is required, and should be in the range of 10K to 100K



**Embedded Results Ltd**  
 P.O. Box 200  
 Aberystwyth,  
 SY23 2WD UK

**Tel: +44 (0) 1974 261 273**  
**Fax: +44 (0) 1974 261 273**  
**Email: sales@kanda.com**  
**Web: www.kanda.com**