

Compatible with
AVR Studio

Operating
Systems (ISP):

- ◆ Win XP
- ◆ Win 2000
- ◆ Win VISTA

Contents:

- ◆ STK300 Board
- ◆ Mounted ATmega128L
- ◆ AVR ISP -U
- ◆ Software on CD
- ◆ Packed in video case

STK300

Complete development system for Atmel
ATmega128 microcontrollers.

AVR[®]

STK300

The STK300 is a complete low-cost system for the Atmel Mega128, ATmega64 and ATmega2561 AVR range of FLASH8-bit programmable RISC microprocessors. The ATmega gives you all the benefits of the AVR plus loads of memory. Included in the Kit is a USB programmer and an editor to simplify code development. Everything is provided for you to develop ATMega designs in a fast track environment.



STK300 board

The STK300 is an optimally designed platform for taking your ATMega design from conception to realisation. The board is populated with switches, LED's, 2 RS232 ports, ADC, port headers and low current dual rail supplies for external Op amps.

A 14-pin connector for standard LCD's, including power and contrast adjustment, is also fitted. The board is prepared for drop-in external RAM connection, with sockets for the Address Latch chip and RAM plus dip header for external memory mapped devices.

Onboard brown out detection and adjustable voltage reference are included. The board has a full range of ports for development purposes.

As the Mega AVR's are only available in surface mount versions, we have mounted the device on a daughter board using standard 0.1" pin headers. The STK300 comes with a mounted ATmega128L device. This has a voltage range of 2.7-5.5V but STK300 board only supports programming at 3.3 and 5V. This daughter board is also available separately.

ISP

The system uses a USB port programmer with 10-way ribbon cable using Kanda standard connection as adopted by Atmel and the ISP software is now an industry standard. The emulation included in the package uses the same hardware so you do not have to worry about cable changes. The ISP is project based to help with file storage and version control.

MISO	SCK	RESET	LED	MOSI
9	7	5	3	1
10	8	6	4	2
GND	GND	GND	GND	Vcc

Kanda.com

Embedded Results Ltd
P.O. Box 200
Aberystwyth,
SY23 2WD UK

Tel: +44 (0) 1974 261 273
Fax: +44 (0) 1974 261 273
Email: sales@kanda.com
Web: www.kanda.com

Order Code:
STK300

Device Support, ISP and sockets on STK300 board:

board:

- ATmega64
- ATmega128
- ATmega2561

ISP support only - board support on STK200:

- ATtiny13
- ATtiny24/44/84
- ATtiny25/45/85
- ATtiny26/261
- ATtiny461/861
- ATtiny26
- ATtiny2313

- ATmega48
- ATmega8
- ATmega88
- ATmega8515
- ATmega8535
- ATmega16
- ATmega161
- ATmega162
- ATmega163
- ATmega168
- ATmega32
- ATmega323

ISP Support only - no board support:

- ATtiny26/261
- ATtiny461/861
- ATmega169

Features

- Mounted ATmega128L device
- Switches and bar LED, with jumper leads to change port
- 2 USART - both available as TTL or RS232 levels
- External Flash RAM socket
- LCD Interface
- 24C EEPROM socket
- ADC support with Internal Reference POT
- ISP and JTAG connectors
- Real Time Clock Crystal
- 3.3 or 5V operation
- Manual, schematics, datasheets, sample programs
- Software including AVR ISP, AVRStudio, C Compiler

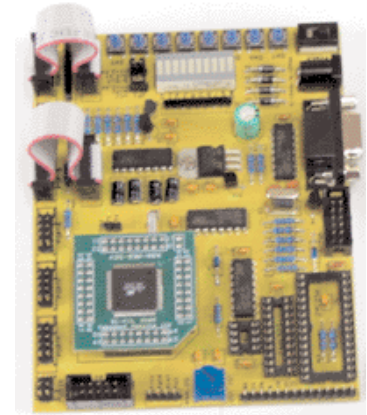

Daughter Board

Extra AVR Mega devices mounted on daughter boards with 0.1" pin headers are available from us.

Product	Part Number
STK300 Kit	STK300
Mounted ATmega64	KANMEGDEV64
Mounted ATmega128	KANMEGDEV5
Mounted ATmega2561	KANMEGDEV256
Mounted ATmega128L	KANMEGDEV3

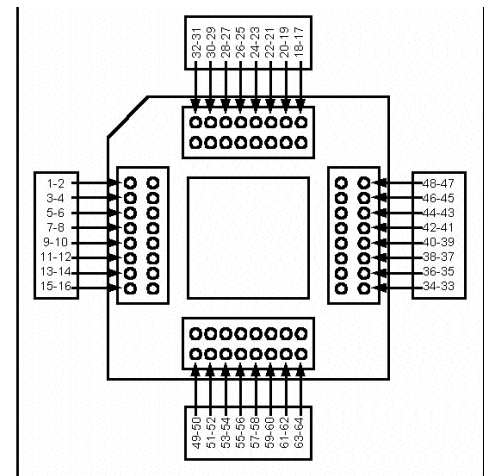

Accessories

Description

Power Supply
RAM Chip set
Intelligent 16 x 2 LCD Module
Data Entry Keypad

Part Number

PSU9V-UNI (9V, 2.1mm barrel)
STK200-RAM
570910-PM
467200-PM

For board support for other AVR devices, see STK200

® AVR is the registered trade mark of Atmel Corporation, Orchard Parkway, San Jose, CA

Related Products

Do also check out our JTAGAVR product. This offers full In Circuit Emulation using JTAG. The STK300 is also available with JTAGAVR included - see STK300ICE.

Kanda.com

Embedded Results Ltd
P.O. Box 200
Aberystwyth,
SY23 2WD UK

Tel: +44 (0) 1974 261 273
Fax: +44 (0) 1974 261 273
Email: sales@kanda.com
Web: www.kanda.com

Order Code:

STK300