

Features

- Portable
- Compact
- One button operation
- 9V Battery or PSU
- Comprehensive device support
- Can power target
- Field use
- Production use
- Supports Lock bits
- Supports 0-5V Vcc
- 256KB memory
- Address Bus
- Selectable page size
- MCU Reset line
- Automatic verify

Device Support:

Programs all 24 and 25 family devices.

Low Voltage types supported

Programs devices from all manufactures - may need to change page size for some devices

Operating Systems

- WIN 95/98
- WIN NT/2000
- WIN ME/XP

Order Codes

Starter Kit:
HH0110EE-P

Programmer:
HH0120EE-P

Serial EEPROM Hand Held Programmer

A battery powered portable ISP in a hand held case, with PSU option



Introduction

The ultimate programming tool for Serial EEPROMs, in the field or on the production line - so easy a child can use it! Just load it once and then program target devices again and again. Programs standalone devices or devices in a microcontroller circuit.

One Starter Kit = Many Programmers

You need one starter kit to load your Hand Held Programmer with settings and code from a PC or laptop, using the simple Wizard software and the printer port connector supplied in the starter kit. Once your programmer is loaded, you can program as many target

devices as you want. It is ideal for field or production use and it is impossible for inexperienced operators to make errors. The single button operation and clear Red/Green LED error indicator prevents mistakes.

Just connect the starter kit to your printer port and run the wizard software. Select your EEPROM data files, device type, lockbit settings and device voltage in the simple Wizard screens and load your code in seconds. As the programmer is battery powered during load, you don't need any power supplies or cabling, just plug a programmer into the extra lead supplied with the starter kit.

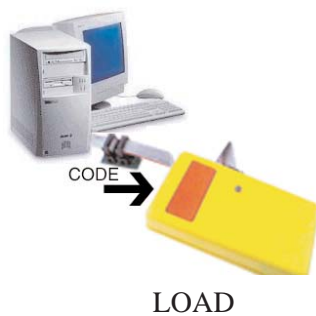

Once a programmer is loaded, it is completely portable and can be used where you need it, not where your PC is located. The programmer will retain your code even if you remove the battery as it is stored in non-volatile memory.



MOVE

For field use, you can use the 9V PP3 battery included. It will even power your target circuit with up to 150mA. Alternatively plug in a 9V power supply and save on battery life.

Programming your targets

To use your programmer on the production line or in the field is so easy! Plug the programmer lead into the 10-way header on the target and press the big red button. During the program and verify operations, the LED flashes green. Once it is finished, a steady green light shows programming and verify was successful. If there were errors, the LED flashes red with a sequence that shows what error occurred: 1 flash = No response from device, 2 = Erase failed, 3 = Program failed, 4 = Fuse write failed. These codes will repeat if the stay on time is set in the software wizard timing screen.

The programmer can supply power to a target board, provided it doesn't draw more than 150mA which is great for field use or adding QA or configuration data at different work stations. Alternatively, the programmer can draw power from the target.



PROGRAM

Kanda.com

Features

- Portable
- Compact
- One button operation
- 9V Battery or PSU
- Comprehensive device support
- Can power target
- Field use
- Production use
- Supports Lock bits
- Supports 0-5V Vcc
- 256KB memory
- Address Bus
- Selectable page size
- MCU Reset line
- Automatic verify

Device Support:

Programs all 24 and 25 family devices.

Low Voltage types supported

Programs devices from all manufactures - may need to change page size for some devices

Operating Systems

- WIN 95/98
- WIN NT/2000
- WIN ME/XP

Order Codes

Starter Kit:

HH0110EE-P

Programmer

HH0120EE-P

Starter Kit Contents

- Hand Held Programmer
- PC Interface (Printer port)
- 10-way Programmer cable
- 10-way PC adapter cable
- Software CD
- Supplied in video case



Software Features

- Supports Windows 95/98/2000/NT/ME/XP
- Simple Wizard software
- Drop-down device selection lists
- Easy data file selection
- Most file formats can be loaded
- Supports all lock bits on 25C devices
- Page size selection for different manufacturers' parts
- Address bus selection for multiple devices
- Microcontroller reset line, low or high
- Select target Voltage, from 0-5V- 0.02V steps
- Click finish to load your programmer

Power Options

There are three power options with the hand held programmer.

1 Programmer powers target.

Select Vcc needed in software wizard during setup(0-5V) and plug into un-powered target. Connector pin 2 (Vcc) must be connected to Vcc on your board. Use battery or external PSU

2 Target Powers Programmer.

Target circuit Vcc line must be connected to Vcc pin on header (Pin 2). Power target.

3. Target and Programmer both powered.

Set Programmer voltage in software wizard to match target voltage. Do NOT connect target Vcc line to Pin 2

Connector

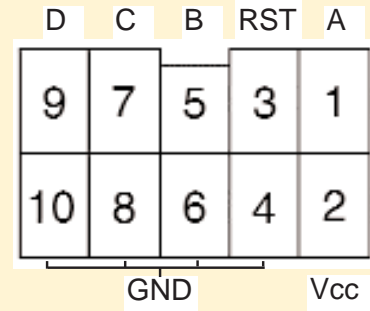

It is recommended that all 4 GND pins are connected to target ground, 0V

24Cxxx

25Cxxx

93Cxxx

A	N/C	SI – Pin 5	DI – Pin 3
B	N/C	NOT CS – Pin 1	CS – Pin 1
C	SCL – Pin 6	SCK – Pin 6	CLK – Pin 2
D	SDA – Pin 5	SO – Pin 2	DO – Pin 4

EEPROM Pin numbers are for 8-pin SOIC and PDIP parts only. Refer to device datasheet for pin-outs of other package types

YOU MUST HAVE A STARTER KIT TO LOAD THE INDIVIDUAL PROGRAMMERS

Programmer Features

- Programmer Size 106 x 58 x 25mm
- Programmer Size 4.5 x 2.5 x 1 inch
- 9V PP3 battery included
- 9V 2.5mm barrel connector for PSU
- Flexible Vcc range - 0 to 5V
- 256KB memory capacity
- Microcontroller reset line
- Non-volatile code storage keeps your data
- Supports 24 and 25 family devices
- Single button operation
- Red/Green error LED

Features

- Portable
- Compact
- One button operation
- 9V Battery or PSU
- Comprehensive device support
- Can power target
- Field use
- Production use
- Supports Lock bits
- Supports 0-5V Vcc
- 256KB memory
- Address Bus
- Selectable page size
- MCU Reset line
- Automatic verify

Device Support:

Programs all 24 and 25 family devices.

Low Voltage types supported

Programs devices from all manufactures - may need to change page size for some devices

Operating Systems

- WIN 95/98
- WIN NT/2000
- WIN ME/XP

Order Codes

Starter Kit:
HH0110EE-P

Programmer
HH0120EE-P

Connecting Programmer to PC

In order to setup the programmer, you require a starter kit.

1. Connect the lead with the larger male connector to PC Adapter (dongle), using the 10-way female connector
2. Plug the PC adapter into the Parallel port on the PC.
3. Use the second lead supplied (with 10-way female connectors on each end) to connect the Programmer to the 10-way male connector on the PC Dongle lead.
4. Run software and follow on screen instructions.

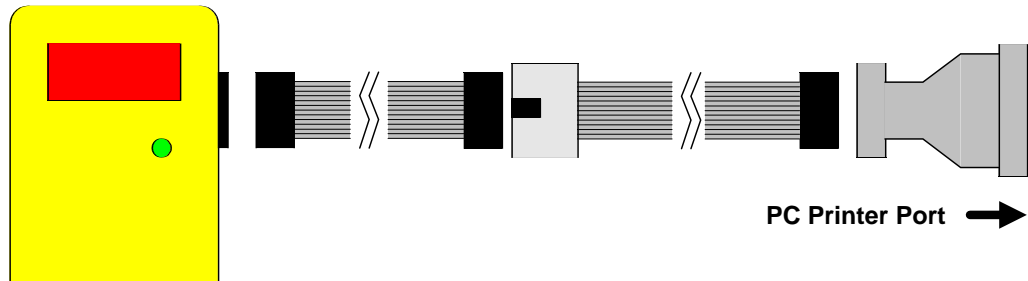

Using other connectors

The standard programmer connector is a 10-way female connector. This plugs on to a 10-way DIL header on the target system i.e. the target connector is a 5 x 2 DIL pin header with 0.1" (2.54mm) pitch. See previous page for pin assignments

To use smaller connectors on the target board e.g. 6-way or 4-way connectors, can not be done by just wiring pin to pin as all the GND pins on the programmer must be wired together - see diagram on right.

The minimum number of pins varies with device family and whether Vcc must be connected - see Power Supply options on page 2.

The minimum number of pins that must be connected is shown here for different families and power options. Note that these figures do not include Microcontroller Reset Line (pin 3) for

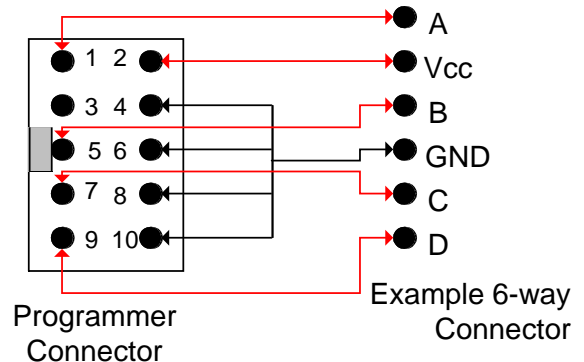

	Target only Powered	Programmer only powered	Target and Programmer powered
24 Family	6	6	5 - no Vcc
25 Family	4	4	3 - no Vcc
93 Family	6	6	5 - no Vcc

any device family, and do include Chip Select (CS) for 24 and 93 families.

Available connectors

Kanda supply several standard connectors with different formats if you require different headers on your target board, rather than fitting the standard 10-way pin header.

Order Code	Product
10MICRM6	10-way to 6-way Micromatch adapter
10DIL6	10-way to 6-way DIL pin header adapter
10FLEX6	10-way to 6 x 1-way pin header - flying leads

Kanda.com

Embedded Results Ltd
P.O. Box 200
Aberystwyth,
SY23 2WD UK

Tel: +44 (0) 1974 261 273
Fax: +44 (0) 1974 261 273
Email: sales@kanda.com
Web: www.kanda.com

Features

- Portable
- Compact
- One button operation
- 9V Battery or PSU
- Comprehensive device support
- Can power target
- Field use
- Production use
- Supports Lock bits
- Supports 0-5V Vcc
- 256KB memory
- Address Bus
- Selectable page size
- MCU Reset line
- Automatic verify

Device Support:

Programs all 24 and 25 family devices.

Low Voltage types supported

Programs devices from all manufactures - may need to change page size for some devices

Operating Systems

- WIN 95/98
- WIN NT/2000
- WIN ME/XP

Order Codes

Starter Kit:

HH0110EE-P

Programmer

HH0120EE-P

Battery

The unit is fitted with a standard 9V PP3 battery. To change the battery:

1. Remove clip-on cover on back of unit.
2. Carefully extract battery and remove from battery clip
3. Replace battery - battery can only be connected with the correct polarity
4. Replace cover

Power Supply

The unit can be used with a power supply instead of the battery. The battery does NOT have to be removed as inserting the power supply disconnects the battery.

The power supply needed is a :

- 9V regulated
- 2.1 mm barrel connector
- Centre positive
- No minimum or maximum current requirements

Note: The unit has a 150 mA overcurrent protection so it cannot supply more current than this to the target, whatever the power supply rating.

A suitable power supply can be purchased on the kanda.com shop

- **Order Code: PSU9V-UNI**

This power supply is universal (90-250 VAC, 47-63Hz) and comes with US, EU, UK and Australian plug fittings.

Order Code Summary

Order Code	Product
HH0110EE-P	Starter Kit with Programmer and PC Adapter plus software
HH0120EE-P	Individual Programmer - you need one starter kit to load as many programmers as you like from PC.
PSU9V-UNI	Universal 9V power supply for use with programmer
10MICRM6	10-way to 6-way Micromatch adapter for Micromatch header on target
10DIL6	10-way to 6-way DIL pin header adapter for 6-way pin header (0.1"/2.54mm) on target
10FLEX6	10-way to 6 x 1-way pin header - 6 colour coded flying leads for flexible connections

YOU MUST HAVE A STARTER KIT TO LOAD THE INDIVIDUAL PROGRAMMERS

Kanda.com

**Embedded Results Ltd
P.O. Box 200
Aberystwyth,
SY23 2WD UK**

**Tel: +44 (0) 1974 261 273
Fax: +44 (0) 1974 261 273
Email: sales@kanda.com
Web: www.kanda.com**