

HAND HELD PROGRAMMER QUICK START GUIDE

IMPORTANT INFORMATION

1) Do not leave the programmer connected to the PC adapter or a target system, as this will drain the battery.

LOADING FROM THE PC

1) Connect the PC adapter (dongle) to the PC parallel port.

2a) Connect the long extension cable, using the end black socket, to the PC adapter. Then connect the programmer to the end grey plug of the extension cable - using the short ribbon cable. This method is useful where access to the PC adapter is poor.

Method 2

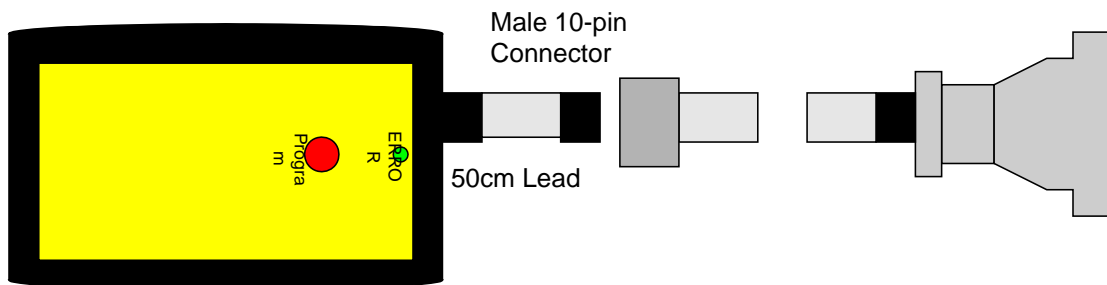

- 1) Connect 50cm lead to Handheld Programmer
- 2) Connect black 10-way female connector (on end of lead) to PC adapter
- 3) Plug 50cm lead into Male 10-way connector

2b) Just connect programmer to Dongle using 50cm cable

Method 1

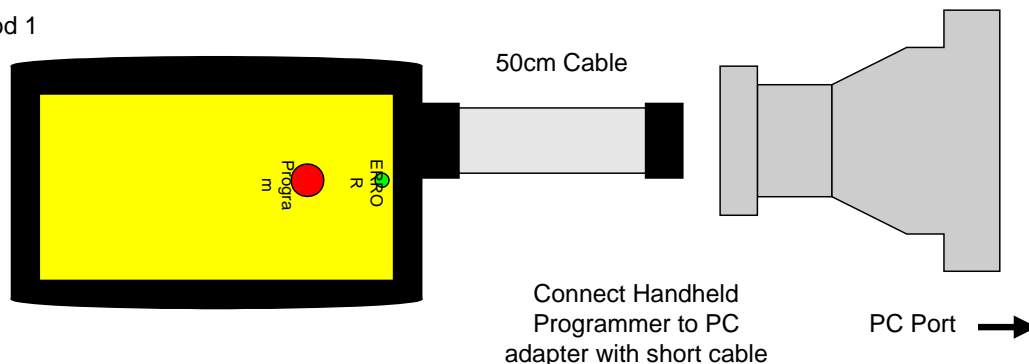

3) To load code, follow the instructions in the software.

PROGRAMMING THE TARGET SYSTEM

3) Install and Run the Handheld Programmer software

- Select the file to use in the filename box.

Notes:

The programmer expects a Microchip type hex file (as produced by MPLAB). The file should contain

- Program Code
- EEPROM data – if PIC device has EEPROM and data is required
- Configuration Bytes including Security information
- User ID if required

See section on Hex File formats for more details

- Now select the device family required (16F or 18F) and the device type
- Choose the Programming Mode, Low voltage (LVP) or High Voltage (HVP). If you choose LVP, you must connect LVP pin – see section on ***Low Voltage Programming.***
Note: Not all PIC devices have LVP mode – check device datasheet
- There are also four check boxes.
 1. **Match Device ID.** Checking this box means the programmer will read the device ID and compare it with the ID of the selected device to ensure they match. Some newer device where there is incomplete information could fail this test. ***See section on Error Codes.***
 2. **Verify Configuration Bytes.** Allows configuration byte programming to be verified. ***See section on Error Codes.***
 3. **Program User ID.** User ID bytes are programmed – PIC18F only. The User ID bytes must be included in the Hex file or all locations will be programmed with 0xFF. ***See section on PIC18F Hex File formats for more detail***
 4. **Preserve Data Memory.** Existing contents of device Data EEPROM are preserved.
- **Error Flash Repeat No:** The green success code or red error codes will repeat this number of times.
- The final step is to click the **Upload** button to load the handheld programmer.

You Programmer is now loaded and ready for use.

If you get errors with connecting to the programmer, see the troubleshooting section at the end of this guide.

CONNECTING TO A TARGET

10-way connector

Connect the programmer to the target system using the short ribbon cable. The programmer has a 10-way connector with the following properties.

- Target Layout – not end of lead view
- Header is 0.1" (2.54mm) box header in 5 x 2 format, with polarising notch
- GND* These pins must be connected to target ground

N/C	9	10	VDD
PGM	7	8	GND
MCLR/Vpp	5	6	GND *
Clock - PGC	3	4	GND *
Data - PGD	1	2	GND

- GND One or both must be connected to Target ground
- VDD must be connected to target circuit Vdd
- PGM pin is only connected for LVP programming

6-way connector

The programmer is supplied with a 10-way to 6-way flying lead adapter. Only 5 off these connections need to be made for HVP programming, as PGM pin is only used for LVP programming. Connect the adapter to the programmer as shown in the diagram

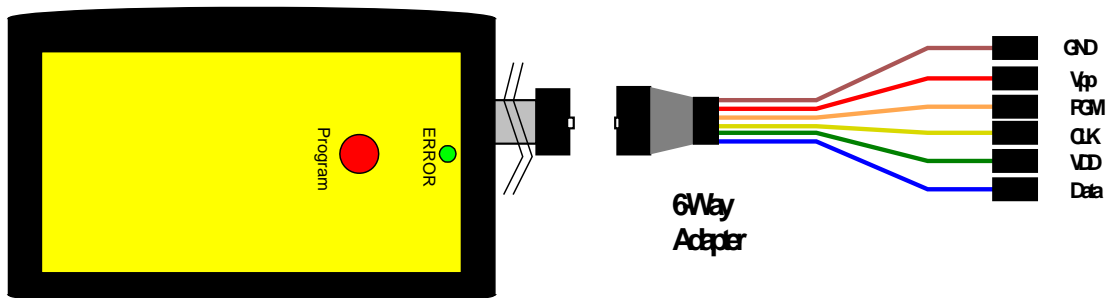

Note: This adapter connects all the GND pins shown in the 10-way connector. If you make your own 10- to 6-way adapter, it should also connect all the GND pins on the programmer lead.

ICSP CIRCUIT REQUIREMENTS

Microchip do not recommend any particular circuit for ICSP programming. There are diagrams for different tools, such as Pro Mate and PICKit2 with similar circuitry but slight variations.

Kanda have produced a recommended circuit that will work effectively with our programmer. This circuit is shown in the diagram below. Please read the notes that explain the circuit and expand on the effect of extra components such as capacitors.

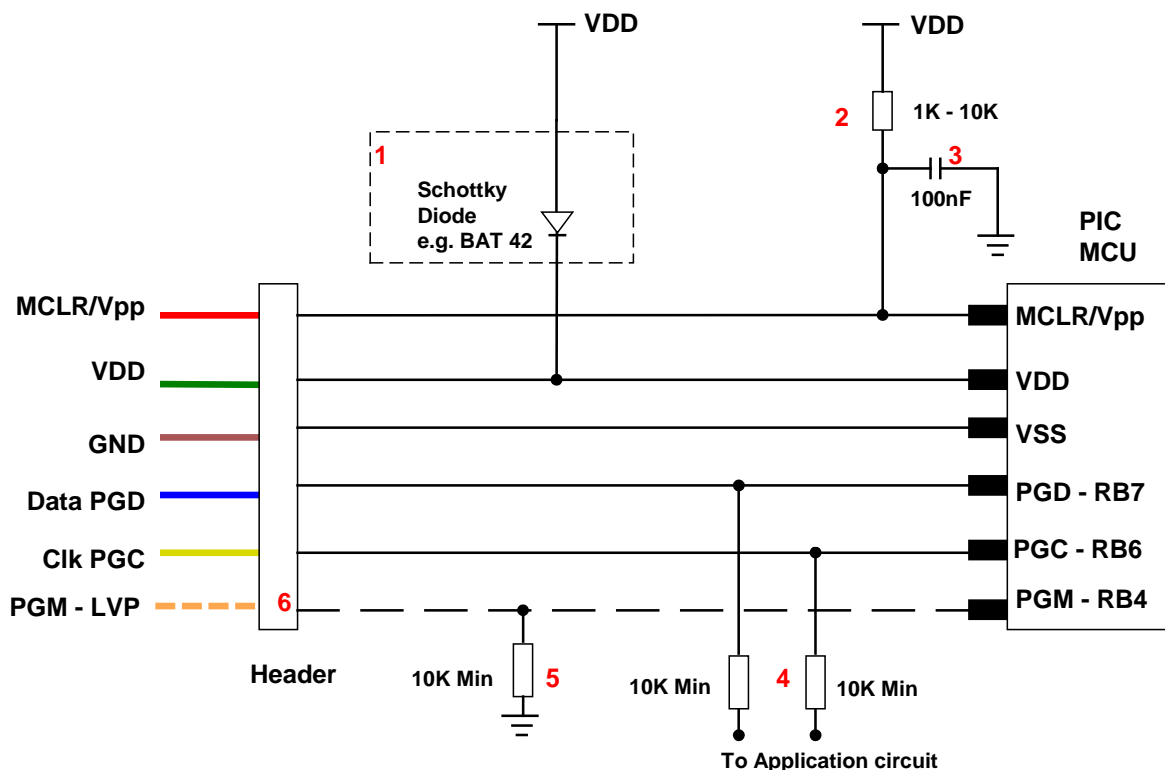

- 1) The programmer is designed to provide 5V to the target circuit. If your circuit operates at a lower voltage then the diode shown on VDD should be fitted to protect the rest of the circuit. A series resistor may be acceptable instead of the diode in some cases.

The maximum current that the programmer can supply is limited to 150mA, so you should fit the diode on VDD if the programmer over-current circuit trips - see *error codes section*

- 2) MCLR/VPP pin needs the resistor to VDD. A minimum of 1K should work but 10K is the optimum. Supervisory circuits or push buttons on MCLR should be isolated from the VPP voltage, by placing them on the VDD side of the resistor or by fitting a Schottky diode on this line as per note 1.
- 3) The 100nF capacitor shown on this pin is optional for HVP but we do recommend that it is fitted if possible to avoid glitches on MCLR. This is the **maximum** value. Larger capacitors may prevent the PIC from entering HVP mode. Do not fit for LVP mode.
- 4) If possible, the Clock and Data lines should be dedicated to ICSP but where this is undesirable, the application circuit should be isolated from the data and clock lines with series resistors, above 10K. This is especially important if either of these lines forces the pin as an input or output. In exceptional cases, series resistors may not be sufficient and a 4053 multiplexer or similar circuit should be used.

Capacitors on these lines should be avoided if at all possible. If they are needed, for noise immunity for example, then the maximum capacitance the programmer can handle is 1nF.

- 5) If LVP mode is used, this resistor must be fitted.
- 6) This line is only needed for Low Voltage Programming – LVP mode.
- 7) PIC18F J parts need a decoupling capacitor between VccCore pin and Ground, typically 100nF

High Voltage Programming

The High Voltage Programming method or HVP mode uses 12V on the MCLR/VPP pin to enter programming mode. The programmer includes a 12V generator circuit that supplies this voltage.

There are two methods of entering HVP mode, Vpp before Vdd and Vdd before Vpp. Both methods are available on some PIC devices, but others only have one of the methods. The programmer will use Vpp first if it is available as it has advantages such as being independent of code in the PIC. This method will only work if the target is NOT powered.

The PGM line does not need to be connected for HVP mode.

The programming mode must be set to High Voltage Programming (HVP) in the software.

Low Voltage Programming

Only some PIC devices have 5V programming – LVP – option. Consult the device data sheet if you are unsure.

Assuming the PIC device has LVP mode, then you need to connect the PGM pin on the PIC to the header and connect the orange programmer line to this header pin. The pull-down resistor on the PGM line must be fitted for LVP to function correctly – see note 5 on diagram.

Notes:

- 1) The LVP enable fuse must be set – in CONFIG4L register. Factory default is LVP enabled. If you program this fuse off, then only HVP mode can set it again.
- 2) The programmer software must be set to Low Voltage mode - LVP

Press the button to start programming.

Once programming is finished, the button can be pressed again to do another programming cycle without unplugging the programmer.

Do NOT leave the programmer connected to target circuits for long periods as this will flatten the battery.

LED Codes

Normal operation:

A single green flash, when first connected. Then, after pressing the button, the LED turns green for the duration of programming. At the end of programming the green LED flashes for 5 seconds and switches off, and the target system is powered down.

If there was an error, the LED will flash RED. These codes repeat several times, but with an interval between groups.

Error codes – LED turns red:

- | | |
|-----------|--|
| 2 flashes | - General verify error |
| 3 flashes | - Data memory did not verify |
| 4 flashes | - Code memory did not verify |
| 5 flashes | - User ID words did not verify * |
| 6 flashes | - Configuration Bytes did not verify * |
| 7 flashes | - Device ID did not match * |

8 flashes - Allowed Program Count reached
Constant Red LED - Low battery or Over-current trip > 150MA

* Only if selected in check box – *see Loading the Programmer section*

If Limit Programs is unchecked, default count is 65535.

HEX FILE FORMAT FOR PIC18F DEVICES

The programmer loads a Microchip format Hex file. This is an extended Intel Hex file with code, data, configuration bytes and user ID included. All PIC tools should follow this format.

Each line in the file has this format:

:BBAAAATT[DDDDDDDD]CC

where

: is start of line marker

BB is number of data bytes on line

AAAA is address in bytes

TT is type. 01 means EOF and 04 means extended address

DD is data bytes, number depends on BB value

CC is checksum (2s-complement of number of bytes+address+data)

- **Code:** This is at the top of the file and may be preceded by an extended address line - :020000040000FA, where 04 is the type for extended address
Some compilers include empty code lines (all FF) but others omit these lines to save space
- **EEPROM Data:** It is preceded by the extended address line - :0200000400F00A. The EEPROM section is optional
- **Configuration bytes:** These are stored at 300000h and are preceded by the extended address line - :020000040030CA
The correct format is 8 Fuse bytes and 6 Lock bytes all on the same line but different compilers and assemblers have different methods of displaying these bytes. Sometimes lock bytes are omitted if they are not set, sometimes the data is spread over multiple lines.
The standard format displays unused bits as 1 (e.g. FF for an unused byte) but on the PIC device they read as 0. The programmer masks unused bits to 0 so that the Configuration Byte verify will be correct.
- **User ID:** These are bytes for the user to store data, such as code version numbers. They are stored at 200000h. Again they are preceded by the extended address line :020000040020DA
The standard format requires 8 bytes but again some compilers omit unused bytes.

- **End of File:** The End Of File marker for all Intel Hex files is :00000001FF
-

HEX FILE FORMAT FOR PIC16F DEVICES

The programmer loads a Microchip format Hex file. This has a similar format to the PIC18F file but does not use extended addressing as the PIC16F devices are smaller.

- **Code:** Code is always at the top of the .hex file. The layout varies with different compilers and assemblers e.g. amount of data per line, whether blank lines are included etc. Note that the PIC16F devices use 14-bit instructions, so code is stored as Words with low byte first. Therefore, an unused location appears as FF3F. Addressing is in bytes though.
 - **EEPROM Data:** If the device has EEPROM, the data is stored at address 0x4200 upwards in the HEX file. It is stored in word format but only the lower byte contains data – the high byte is always 0 and is discarded.
 - **Configuration Word:** There is only one 14-bit configuration word, stored at address 0x400E. It is stored high byte first.
 - **End of File:** The End Of File marker for all Intel Hex files is :00000001FF
-

BATTERY AND POWER SUPPLY

The Handheld Programmer uses a standard 9V PP3 battery. These are commonly available.

The Handheld Programmer can also be powered from an external Power Supply. The power supply should be

- 2.1mm barrel connector (coaxial plug), centre positive.
- 9V DC regulated
- 300 mA plus

A universal PSU or Wall Transformer is available on the Kanda shop –
Order Code PSU9V-UNI

TROUBLESHOOTING

Error message: “Dongle was not detected – check connections and parallel port settings”

- 1) Ensure dongle (PC adapter) is connected to printer port
- 2) Check port setting – LPT1, LPT2 etc.
- 3) In BIOS, make sure port is set to EPP v1.9 or ECP
- 4) Some versions of XP poll printer port, which affects programming. if you get verify failures when loading programmer, make sure you install software with Disable Polling enabled

Error Message: “Programmer is not responding – check connections and battery power”

- 1) Check that programmer is connected to PC as shown on Page 1
- 2) Check battery or power supply to the programmer
- 3) Make sure you have a Handheld Programmer or keyfob dongle, not a standard AVRISP/STK200 dongle. The keyfob dongle has a pin missing on 10-way connector

Programming Errors – RED Flashes on LED when programming

- 1) Ensure your target circuit is wired correctly as discussed in the *ICSP Circuit Requirements* section.
- 2) Check you have correct device selected, especially if ID match is turned off
- 3) Ensure you have selected LVP or HVP as appropriate
- 4) Check programmer is powering target PIC with 5V on VDD pin and 12V+ on VPP pin for HVP or 5V on PGM pin for LVP, during programming
- 5) Check lead connections on programming header are correct

Programming Errors – Constant RED LED

This means a low battery or that the over-current circuit has tripped

- 1) Check battery or power supply to programmer is ok
 - 2) Isolate circuitry (with a Schottky diode – see diagram on page 4) that is drawing too much current, as the programmer is limited to 150mA
-

FURTHER INFORMATION

Please contact support@kanda.com for technical support or go to our website support pages for latest software.

See www.kanda.com/support > Software Downloads

Contact details

Website: www.kanda.com

email: sales@kanda.com

Phone/Fax: +44 (0)1974 261 273



PICmicro, Microchip, ICSP are registered trade marks or trade marks of Microchip Corp, Az, USA