

**QuickUSB<sup>®</sup>**  
*User Guide*

**Bitwise<sup>™</sup>**  
SYSTEMS

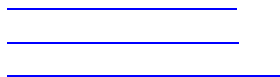

QuickUSB User Guide  
Version 2.11.35  
April 28, 2006

Copyright © 2005, 2006 Bitwise Systems. All rights reserved. This document contains confidential information and trade secrets of Bitwise Systems, and is protected by United States and international copyright laws. Use, disclosure, or reproduction is prohibited without the prior express written permission of Bitwise Systems, except as agreed in the License Agreement. Use, duplication or disclosure by the U.S. Government is subject to restrictions as provided in DFARS 227.7202-1(a) and 227.7202-3(a) (1998), and FAR 12.212, as applicable.

# Table of Contents

<b><u>Introduction</u></b>	<b><u>1</u></b>
<b><u>QuickUSB and the Big USB Picture</u></b>	<b><u>1</u></b>
USB Nomenclature	1
USB System Architecture	1
I/O Subsystem Latency and Throughput	2
USB Interpacket Delay	2
<b><u>Designing Hardware for QuickUSB</u></b>	<b><u>3</u></b>
The Cypress EZ USB FX2	3
Power and Ground	3
Unused I/O Pins	4
Default I/O State	4
High Speed Parallel Port	4
Overview	4
GPIF Master Mode	5
GPIF Master Mode I/O Models	6
Slave FIFO I/O Models	16
FPGA Configuration	21
General-Purpose I/O Pins	21
RS-232	21
I2C	21
SPI	22
QuickUSB Pin Definitions	23
<b><u>Using the QuickUSB Library</u></b>	<b><u>39</u></b>
Overview	39
How to Communicate with a Module	39
System Considerations	40
Blocking versus Non-blocking Data Transfers	40
QuickUSB Base API	41
QuickUsbFindModules	41
QuickUsbOpen	41
QuickUsbClose	42
QuickUsbGetStringDescriptor	42
QuickUsbSetTimeout	43
QuickUsbGetDriverVersion	43
QuickUsbGetDllVersion	43
QuickUsbGetFirmwareVersion	44
QuickUsbGetLastError	44
QuickUSB Settings	45
QuickUsbReadSetting	51
QuickUsbWriteSetting	51
QuickUsbReadDefault	52
QuickUsbWriteDefault	52
FPGA Configuration	53
QuickUsbStartFpgaConfiguration	53

QuickUsbWriteFpgaData	54
QuickUsbIsFpgaConfigured	54
High-Speed Parallel Port	55
QuickUsbReadCommand	55
QuickUsbWriteCommand	56
QuickUsbReadData	57
QuickUsbWriteData	58
QuickUsbReadDataAsync	59
QuickUsbWriteDataAsync	60
QuickUsbAsyncWait	61
General-Purpose I/O	62
QuickUsbReadPortDir	62
QuickUsbWritePortDir	62
QuickUsbReadPort	63
QuickUsbWritePort	63
RS-232	64
QuickUsbSetRs232BaudRate	64
QuickUsbGetNumRS232	64
QuickUsbFlushRS232	65
QuickUsbReadRS232	65
QuickUsbWriteRS232	66
I2C-Compatible Port	67
QuickUsbReadI2c	67
QuickUsbWriteI2c	67
SPI-Compatible Port	68
QuickUsbReadSpi	68
QuickUsbWriteSpi	68
QuickUsbWriteReadSpi	69

## Introduction

Thank you for choosing QuickUSB®. QuickUSB makes your product a well-connected USB device quickly and with a minimum of hassle. Not only is QuickUSB a quick way to get connected to USB, it also offers great Hi-Speed USB 2.0 performance with a wide variety of target interface options.

We hope this guide will answer all of your questions about QuickUSB. However, if you have a question that you cannot find an answer for in this guide, please check the web site at [www.quickusb.com](http://www.quickusb.com) and please use the QuickUSB online support forum. Our support team will do our best get you the answer you need.

## QuickUSB and the Big USB Picture

Please take some time to understand the big picture as it relates to USB connections. USB has gained the success it has because it is a well-designed bus specifically designed to easily, and reliably connect peripherals to a PC. Part of that design defines the relationship between your PC and the device. Although with QuickUSB you do not need to learn the inner workings of USB, you do need to understand the basics of USB. We will explain the basics here and if you want to learn more, you can browse [www.usb.org](http://www.usb.org) and learn just about everything that there is to know about USB. Just be careful, because you can easily get distracted from what you really need to accomplish.

## USB Nomenclature

Conveying the big picture requires defining some key words. The first is USB and it is an acronym for Universal Serial Bus. Host means your PC. Device means the QuickUSB module and/or the subsystem you need to connect to the PC. A pipe is a unidirectional virtual connection between a host and the device. Every pipe has a direction attribute of either IN or OUT to indicate the direction of data flow *with respect to the host*. An endpoint is the device side connection of a pipe. When a device is connected to a host, the host automatically senses this and enumerates the bus to find it.

## USB System Architecture

The USB is a master/slave bus. This means that the master initiates all traffic on the bus and the slave can only respond to the master. For the USB, the master is the host computer (your PC) and the slave is the device. This master/slave relationship means that interrupts are not possible on the USB. The USB supports a pseudo-interrupt scheme involving low-latency *interrupt endpoints* so the host can perform low-latency device polling to emulate an interrupt. QuickUSB does not currently support interrupt endpoints.

### I/O Subsystem Latency and Throughput

The period of time between the start of a transfer and the time that it actually occurs is the *transfer latency*. USB transfer latency is the result of several factors. First is the fact that the USB is a frame oriented bus and that all packets must be scheduled to a timebase of either 1ms (full speed) or 125us (Hi-Speed). Secondly, the operating system generally assesses a software latency penalty when switching from user mode to kernel mode.

*Throughput* is a measure of data transfer speed and is generally expressed in megabytes per second (MB/s). Transfer latency affects throughput because it increases the amount of time a transfer takes regardless of the connection speed.

However, as the data transfer size becomes larger, the transfer latency becomes a smaller fraction of the total transfer time thereby diminishing its effect. When the transfer size is small, the transfer latency will seriously degrade throughput.

Therefore, for applications that require the highest throughput, transfer sizes of at least 64KB are recommended.

Another way to mitigate transfer latency issues is to minimize the amount of time that the USB subsystem waits to schedule USB packets. You can accomplish this using asynchronous function calls. With asynchronous function calls, the transfer is scheduled when the function is called, but the function returns without waiting for the transfer to complete. Using this mechanism, one can concurrently schedule enough USB transfers to assure that the USB will not idle waiting for data to be transferred to or from your device.

The simplest and most reliable technique for this is to employ multiple transfer buffers and rotate them on an as-needed basis.

### USB Interpacket Delay

In certain circumstances, the USB target interface bandwidth is greater than the USB bus bandwidth. This is the case with the Cypress EZ-USB FX2LP microcontroller. In word-wide mode, the FX2LP can transfer data at up to 96MB/sec. The maximum theoretical throughput of a Hi-Speed USB 2.0 pipe is 54MB/sec. Because the FX2LP can go faster than the USB pipe, the target interface is subject to periods of bus inactivity ('gaps') between data packets. Your system design should take into consideration the strong that there will be gaps between data packets and deal with them accordingly.

# Designing Hardware for QuickUSB

Connecting QuickUSB to your hardware is simple. First, decide on the type of connection you need. If you need to transfer large amounts of data very quickly, then you should use the High Speed Parallel Port. If you only need to turn some I/O pins on and off, you can just use the general-purpose I/O pins.

## The Cypress EZ USB FX2

QuickUSB is based on the Cypress EZ-USB FX2LP microcontroller. The FX2LP is a powerful, single-chip USB microcontroller that offers an unparalleled capability to interface subsystems to a PC with a high-speed USB 2.0 connection. QuickUSB unleashes the power of the FX2LP to high-level hardware and software designers by abstracting its capabilities as library of dataflow oriented function calls. In addition, chip-specific capabilities are supported via 'Settings' that allow the user to customize the behavior of the FX2LP to suit the target application.

## Power and Ground

QuickUSB supplies unregulated +5V at up to 400 mA max on the VBUS pins to power your circuitry. For modules Rev A1 and above, an FET on the QuickUSB module controls power. Power is off by default and then turned on once the host configures the module. This behavior is required by the USB specification. The QuickUSB module incorporates a current limiting circuit that will shut down the VBUS pins on an over-current condition. In addition the entire module may be powered down by the host or a USB hub if it draws more than the 500 mA allotted by the USB.

If your circuit draws less than 400 mA, you may power it from the unregulated 5V provided on the VBUS pins. However, if your circuit will draw more than 50 mA, you should design your circuit with either a downstream power switch (such as the TPS2051A) or an active high enable logic switched voltage regulator. Connect the enable signal to SW\_PG (pin 76). This signal will enable your circuit's voltage regulator once the VBUS switch is turned on and the output voltage has stabilized to  $\geq 93\%$  of the voltage supplied by the USB. For more information about the QuickUSB VBUS switch, consult the datasheet for the Texas Instruments TPS2150.

If your circuit draws more than 400 mA, do not power it from VBUS. It should be powered with an external power supply and connect the digital ground of your circuit to GND. In this case, you might want to connect an unused I/O pin to the external power supply through a current limiting resistor (10K) so you can read the pin to determine the state of the external power supply.

### Unused I/O Pins

Some I/O pins are reserved for future use and may be activated by a new version of the module or a new firmware release. Therefore, you must not connect unused QuickUSB I/O pins to any signals or power supplies. **DO NOT DIRECTLY GROUND UNUSED QUICKUSB I/O PINS IN YOUR CIRCUIT.** You may use a 10k resistor to tie unused pins to a known level, but do not connect them directly.

### Default I/O State

With QuickUSB Library (including firmware) v2.11 and above, QuickUSB supports non-volatile I/O pin default settings. The default settings are programmed and read using the `QuickUsbWriteDefault` and `QuickUsbReadDefault` functions respectively.

### High Speed Parallel Port

The High-Speed parallel port is a truly outstanding feature of the QuickUSB module. It is the fastest connection on the QuickUSB module and can transfer very large blocks of data to and from your device with ease. It provides both master and slave mode transfers with several types of transfer handshaking models.

#### Overview

The high-speed parallel port (HSPP) is an 8 or 16-bit port that is used to transfer high-speed data between the host PC and your device. The `WORDWIDE` setting controls the data element width. If `WORDWIDE = 1`, the transfers are 16-bits wide and if 0, 8-bits wide. For more information about `WORDWIDE`, see the [SETTING\\_WORDWIDE](#) setting in the 'Settings' section of this document. If the HSPP is in 8-bit mode, the upper 8 bits may be used as general purpose I/O.

In addition, there is a 9-bit address bus which increments each time a data element is transferred. The address bus can be set to a fixed address to allow multiple writes to the same address. The address bus can also be disabled and the address bus bits reused as general purpose I/O. See the [SETTING\\_DATAADDRESS](#) setting in the 'Settings' section of this manual for more information

There are two modes of HSPP operation, master and slave. The HSPP mode is automatically selected by the QuickUSB firmware, but it may be changed at any time using the [SETTING\\_FIFO\\_CONFIG](#) setting. Typically, your hardware will be configured for either master or slave mode and the requirements of your application will determine which mode is best for you.

### **GPIF Master Mode**

In GPIF master mode, the QuickUSB module controls all aspects of the HSPP and the host PC initiates all data transfers through the QuickUSB module. This mode is implemented using the GPIF programmable DMA engine built into the FX2. All GPIF master mode HSPP transfers are synchronous with IFCLK and are controlled by CMD\_DATA, REN, WEN and OE. CMD\_DATA indicates whether the HSPP transfer was initiated by the command or data functions. REN indicates read a transfer and WEN indicates a write transfer. OE indicates a read transfer prior to actually asserting the REN signal so that the peripheral can prepare to execute a read transfer.

### **Command Transfers**

Command transfers are low-speed transfers that use the data bus (FD) and the address bus (GPIFADR) to read and write data to and from the target hardware. The [QuickUsbReadCommand](#) and [QuickUsbWriteCommand](#) functions are used to perform command transfers. They transfer data one element at a time with the CMD\_DATA line set high ('1'). Command transfers were designed to control registers in a peripheral connected to the HSPP, but they can be used for any type of bi-directional low speed parallel I/O.

### **Data Transfers**

Data transfers are high-speed block-oriented data transfers that use the data bus (FD) and the address bus (GPIFADR) to read and write data to either a FIFO or a memory in the target hardware. The [QuickUsbReadData](#) and [QuickUsbWriteData](#) functions are used to perform high-speed data transfers. They transfer data in a burst of data blocks with the CMD\_DATA line set low ('0'). A single call from QuickUsbReadData or QuickUsbWriteData will be broken down into a series of data blocks transferred over the HSPP.

## GPIF Master Mode I/O Models

The QuickUSB module interfaces to target hardware by implementing a number of I/O models that provide enough flexibility to interface to a wide variety target hardware. The I/O models are selected by reprogramming the firmware of the QuickUSB module using the QuickUSB Programmer. Each firmware load implements a different I/O model. The timing diagrams for each I/O model are given below.

QuickUSB Signal	I/O Model
FD[15:0] (Word Wide) or FD[7:0] (Byte Wide)	All
IFCLK	All
CMD_DATA	All
REN or nREN	All
WEN or nWEN	All
nEMPTY	FIFO & Block
nFULL	FIFO & Block
nOE	FIFO & Block

Table 1 – GPIF Master Mode I/O Connections

## GPIF Master Mode Timing Parameters

Parameter	Description	Internally Sourced IFCLK		Externally Sourced IFCLK		Unit
		Min	Max	Min	Max	
tIFCLK	IFCLK Period	20.83		20.83	200	ns
tSRY	RDYX to Clock Set-up Time	8.9		2.9		ns
tRYH	Clock to RDYX Hold Time	0		3.7		ns
tSGD	GPIF Data to Clock Set-up Time	9.2		3.2		ns
tDAH	GPIF Data Hold Time	0		4.5		ns
tSGA	Clock to GPIF Address Propagation Delay		7.4		11.4	ns
tXGD	Clock to GPIF Data Output Propagation Delay		11		15	ns
tXCTL	Clock to CTLX Output Propagation Delay		6.7		10.7	ns

Table 2 – GPIF Master Mode Timing Parameters

## Simple I/O Model

This I/O model performs transfers without regard to the readiness of the target hardware. This model is suitable for hardware that is always ready and that can transfer data as fast as the host can deliver it. This is the fastest QuickUSB I/O model available.

The Simple I/O model is backwards compatible with all default QuickUSB firmware files.

This I/O model is implemented in the QuickUSB firmware file 'quickusb-simple vX.XX.qusb' where X.XX is the firmware version number.

The Simple I/O model is designed to provide the highest possible data rate that the hardware can provide.

**AS A RESULT, THERE ARE CERTAIN INVALID TRANSFER LENGTHS THAT MAY RESULT IN A FATAL SOFTWARE ERROR WHICH MAY CRASH YOUR COMPUTER.**

The simplest valid transfer length calculation is to request data transfer lengths in multiples of 512 bytes for Hi-Speed mode or 64 bytes for Full-Speed mode. For applications that cannot use this simplified method, see the Notes section below.

## Command Transfers

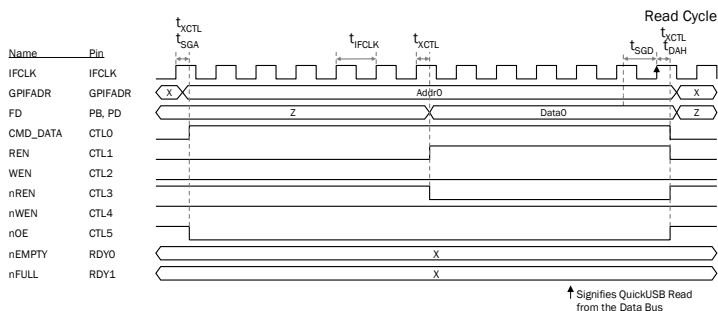
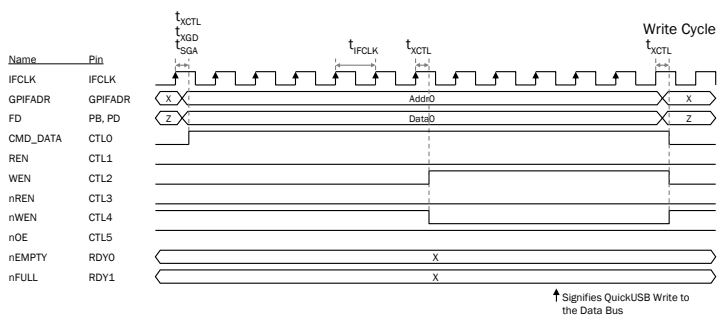

# Designing Hardware for QuickUSB

## Data Transfers

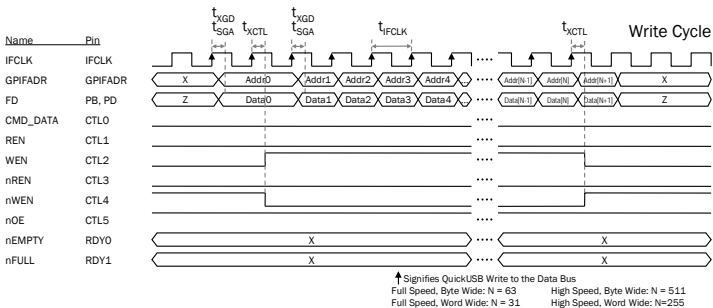
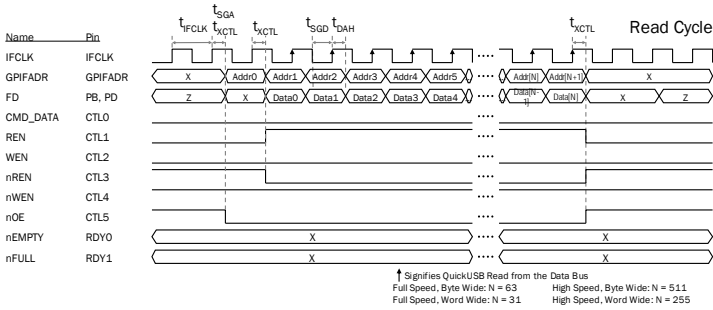

## Notes

The valid data transfer length for the Simple I/O model can be calculated with the following pseudo code:

If (DesiredLength MOD PacketSize <= PreRead) Then

ValidLength = PreRead

Else

ValidLength = DesiredLength

Where:

DesiredLength = The desired transfer length

Valid = The valid transfer length

PreRead = 2 for Byte Wide Mode, 4 for Word Wide Mode

PacketSize = 512 for Hi-Speed, 64 for Full-Speed

## FIFO Handshake I/O Model

This I/O model is designed specifically to allow QuickUSB to connect directly to external synchronous or asynchronous FIFOs. This I/O model is ideal for applications that combine QuickUSB with an FPGA. The QuickUsbRead/WriteData functions read or write streaming data to FIFOs inside the FPGA while the QuickUsbRead/WriteCommand functions control a register array inside the FPGA to manage internal FPGA operations.

With this I/O model, you simply instantiate a FIFO in the FPGA and connect the data and control lines to the QuickUSB module. Please note the FIFO timing requirements given in the 'Data Transfers' section.

This I/O model is implemented in the QuickUSB firmware file 'quickusb-fifohs vX.XX.qusb' where X.XX is the firmware version number.

## Command Transfers

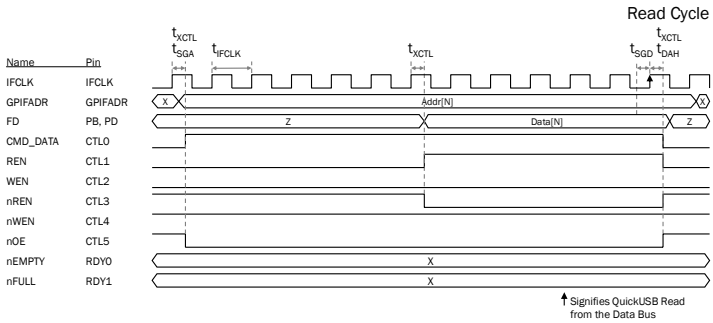
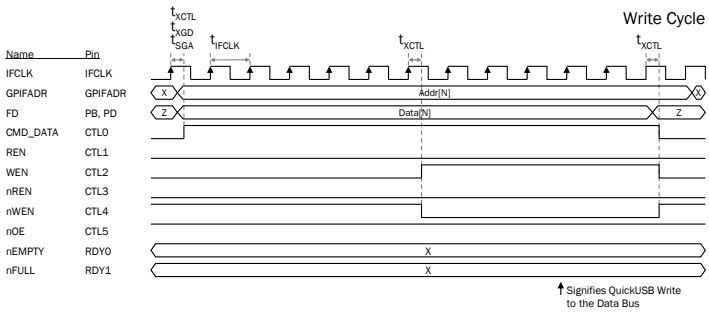



## Full Handshake I/O Model

The full handshake I/O model is ideal for connecting a device that has a very slow or variable transfer time. The module checks the state of the READY signal before each state transition and thereby guarantees that the module and target will be properly synchronized at all times.

This I/O model is implemented in the QuickUSB firmware file 'quickusb-fullhs vX.XX.qusb' where X.XX is the firmware version number.

## Command Transfers

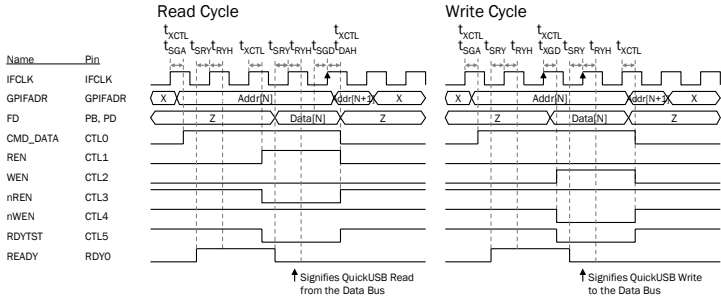

## Data Transfers

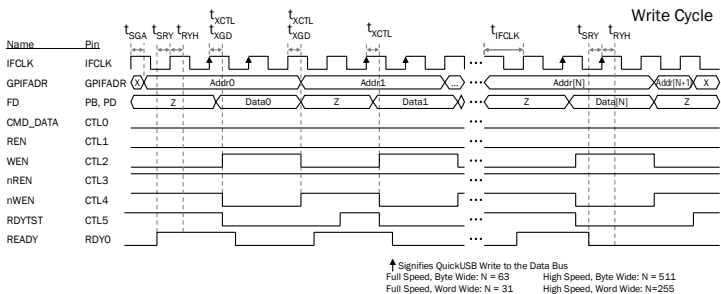
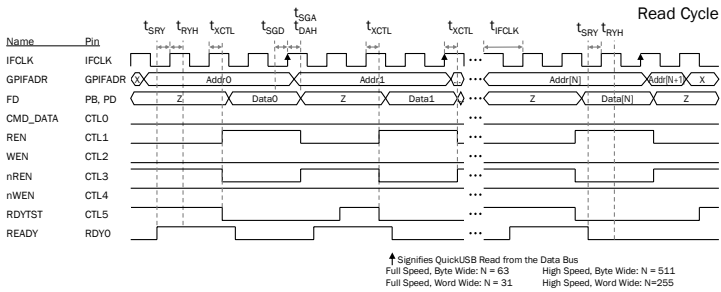

# Designing Hardware for QuickUSB

## Block Handshake I/O Model

Block handshake I/O model is best used for targets that need the benefits of FIFO handshake but always transfer either 64 (Full Speed) or 512 (Hi-Speed) byte blocks for each transaction. This I/O model checks the FIFO flags just once at the beginning of the block and assume that it can transfer the entire block.

This I/O model is implemented in the QuickUSB firmware file 'quickusb-blockhsh vX.XX.qusb' where X.XX is the firmware version number.

The Block I/O model is designed to provide the highest possible data rate possible with hardware handshaking.

**AS A RESULT, THERE ARE CERTAIN INVALID TRANSFER LENGTHS THAT MAY RESULT IN A FATAL SOFTWARE ERROR WHICH MAY CRASH YOUR COMPUTER.**

The simplest valid transfer length calculation is to request data transfer lengths in multiples of 512 bytes for Hi-Speed mode or 64 bytes for Full-Speed mode. For applications that cannot use this simplified method, see the Notes section below.

## Command Transfers

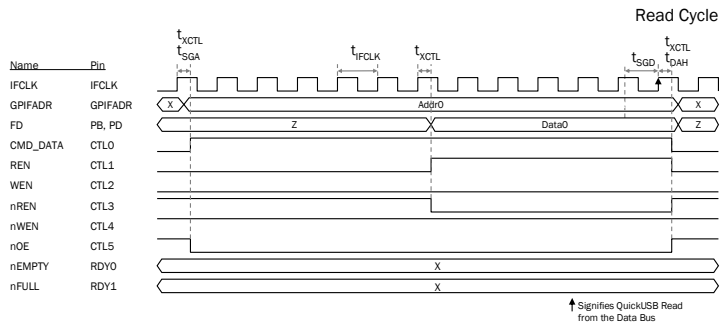
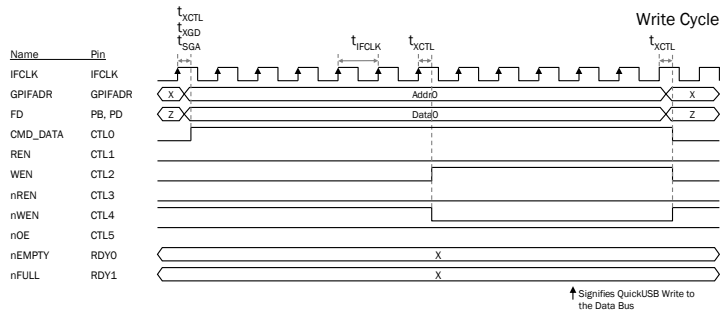

# Designing Hardware for QuickUSB

## Data Transfers

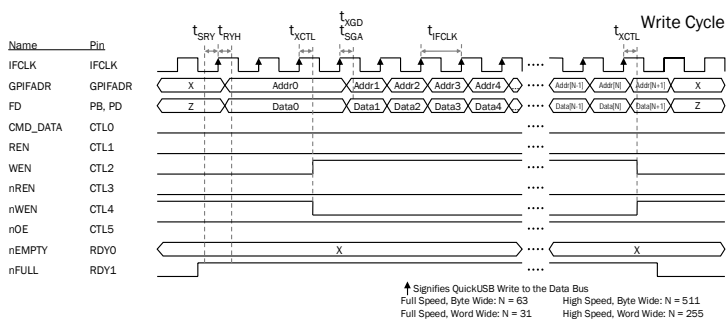
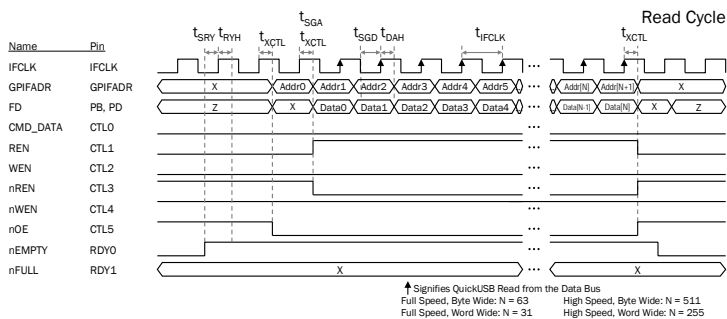

## Notes

The valid data transfer length for the Simple I/O model can be calculated with the following pseudo code:

If (DesiredLength MOD PacketSize <= PreRead) Then

ValidLength = PreRead

Else

ValidLength = DesiredLength

Where:

DesiredLength = The desired transfer length

Valid = The valid transfer length

PreRead = 2 for Byte Wide Mode, 4 for Word Wide Mode

PacketSize = 512 for Hi-Speed, 64 for Full-Speed

# Designing Hardware for QuickUSB

## Pipeline I/O Model

This I/O model implements a one-stage read pipeline. It performs transfers without regard to the readiness of the target hardware. This model is suitable for hardware that is always ready and that can transfer data as fast as the host can deliver it. With this I/O model, the data is transferred one clock cycle after the transfer is made via REN or WEN.

This I/O model is implemented in the QuickUSB firmware file 'quickusb-pipe1 vX.XX.qusb' where X.XX is the firmware version number.

The Pipeline I/O model is designed to provide the highest possible data rate possible with hardware handshaking.

**AS A RESULT, THERE ARE CERTAIN INVALID TRANSFER LENGTHS THAT MAY RESULT IN A FATAL SOFTWARE ERROR WHICH MAY CRASH YOUR COMPUTER.**

The simplest valid transfer length calculation is to request data transfer lengths in multiples of 512 bytes for Hi-Speed mode or 64 bytes for Full-Speed mode. For applications that cannot use this simplified method, see the Notes section below.

## Command Transfers

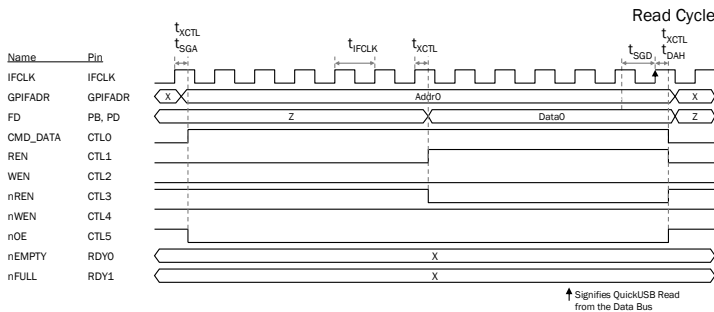
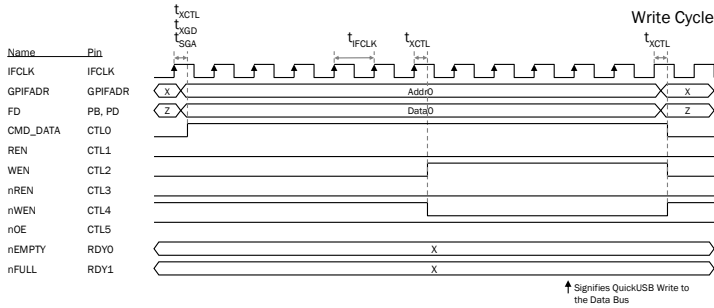

# Designing Hardware for QuickUSB

## Data Transfers

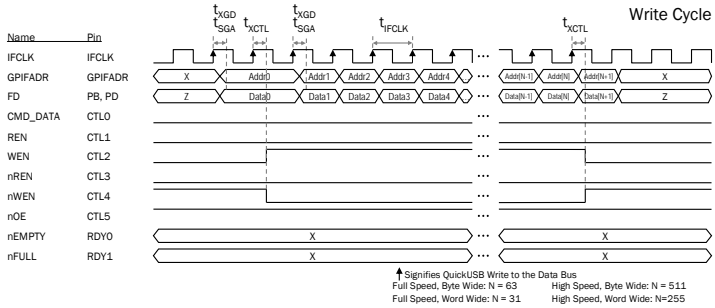
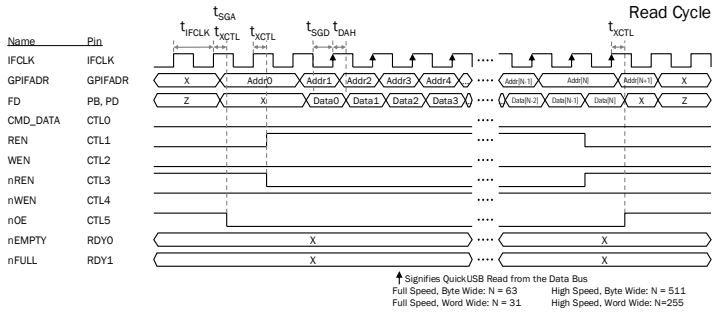

## Notes

The valid data transfer length for the Simple I/O model can be calculated with the following pseudo code:

If (DesiredLength MOD PacketSize <= PreRead) Then

ValidLength = PreRead

Else

ValidLength = DesiredLength

Where:

DesiredLength = The desired transfer length

Valid = The valid transfer length

PreRead = 2 for Byte Wide Mode, 4 for Word Wide Mode

PacketSize = 512 for Hi-Speed, 64 for Full-Speed

## Slave FIFO I/O Models

The HSPP may also be operated in ‘Slave FIFO’ mode. In this mode, the GPIF programmable DMA engine is disabled and the QuickUSB FIFOs are controlled directly by external logic signals. GPIF master mode command/data transfers are not applicable in slave FIFO mode since the GPIF programmable DMA engine is disabled. Slave FIFO mode is selected by changing Bits1-0 of the [SETTING\\_FIFO\\_CONFIG](#) setting and may be changed at any time. In slave FIFO mode, data is transferred to and from the QuickUSB FIFOs using the standard [QuickUsbReadData](#) (EP6) & [QuickUsbWriteData](#) (EP2) functions. These endpoints are double-buffered by default. The QuickUSB module can be configured to perform slave FIFO transfers in either synchronously or asynchronously by changing Bit 3 of the [SETTING\\_FIFO\\_CONFIG](#) setting. The slave FIFO flags may be queried using the [SETTING\\_SLAVEFIFOFLAGS](#) setting.

The following signals are required for slave mode operation:

Pin Name	Alternate Name	Description	Default Config
IFCLK	IFCLK	Clock for synchronous I/O	Rising edge
FD[15:0]	PD[7:0], PB[7:0]	Bi-directional FIFO data bus	N/A
CTL0	FLAGA	Programmable level flag (Half-full)	Indexed mode
CTL1	FLAGB	FIFO Full Status Flag	Indexed mode
CTL2	FLAGC	FIFO Empty Status Flag	Indexed Mode
PA2	nSLOE	Enables the FD outputs for the selected OUT FIFO	Synchronous, Active low
RDY0	nSLRD	FIFO read enable/clock	Synchronous, Active low
RDY1	nSLWR	FIFO write enable/clock	Synchronous, Active low
PA6	nPKTEND	Indicates the end of a short IN packet	Synchronous, Active low
PA7	nSLCS	FIFO Chip Select	Synchronous, Active low
PA5:PA4	FIFOADR[1:0]	Selects the active FIFO for FD and flags. 00=EP2, 01=EP4,10=EP6, 11=EP8	N/A

Table 3 - Slave FIFO Mode I/O Connections

There are three Slave FIFO I/O Models available with QuickUSB. For Slave FIFO Modes, no special firmware file is required. Simply use the Simple I/O Model firmware file and program the [SETTING\\_FIFO\\_CONFIG](#) bit appropriately to implement the desired I/O model.

## Synchronous Slave FIFO I/O Model

This I/O Model performs all transfers synchronously with IFCLK. This model is configured by setting the [SETTING\\_FIFO\\_CONFIG](#) bits IFCFG (bits 0-1) to '11' to go to Slave FIFO Mode and ASYNC (bit 3) to '1' to make all transactions synchronous to IFCLK.

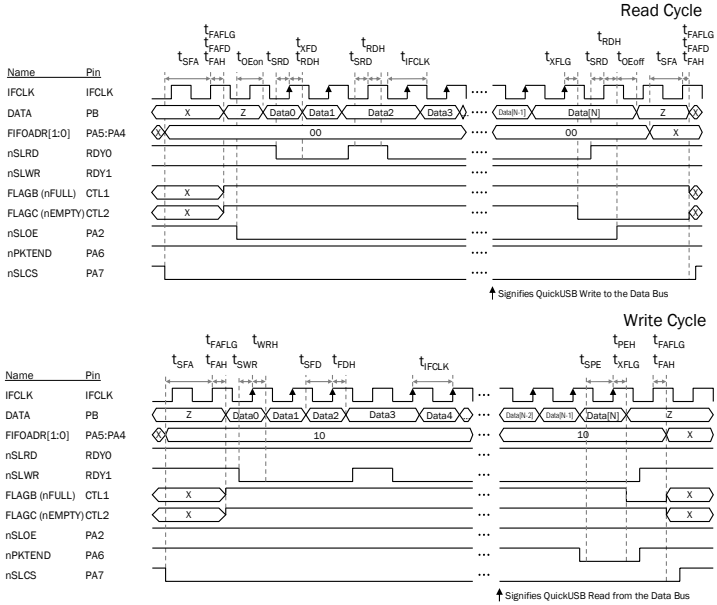

Figure 1 - Synchronous Slave FIFO I/O Timing Diagrams

## Designing Hardware for QuickUSB

Parameter	Description	Internally Sourced IFCLK		Externally Sourced IFCLK		Unit
		Min	Max	Min	Max	
tIFCLK	IFCLK Period	20.83		20.83	200	ns
tSRD	SLRD to Clock Set-up Time	18.7		12.7		ns
tRDH	Clock to SLRD Hold Time	0		3.7		ns
tOEon	SLOE Turn-on to FIFO Data Valid		10.5		10.5	ns
tOEoff	SLOE Turn-off to FIFO Data Hold		10.5		10.5	ns
tXFLG	Clock to FLAGS Output Propagation Delay		9.5		13.5	ns
tXFD	Clock to FIFO Data Output Propagation Delay		11		15	ns
tSWR	SLWR to Clock Set-up Time	18.1		12.1		ns
tWRH	Clock to SLWR Hold Time	0		3.6		ns
tSFD	FIFO Data to Clock Set-up Time	9.2		3.2		ns
tFDH	Clock to FIFO Data Hold Time	0		4.5		ns
tSFA	FIFOADR and nSLCS to Clock Set-up Time	25				ns
tFAH	Clock to FIFOADR and nSLCS Hold Time	10				ns
tFAFLG	FIFOADR to FLAGS Output Propagation Delay		10.7			ns
tFAFD	FIFOADR to FIFO Data Bus Propagation Delay		14.3			ns
tSPE	PKTEND to Clock Set-up Time	14.6		8.6		ns
tPEH	Clock to PKTEND Hold Time	0		2.5		ns

Table 4 – Synchronous Slave FIFO Timing Parameters

## Asynchronous Slave FIFO I/O Model

This I/O Model performs all transfers asynchronously using only the rising/falling edge of the nSLRD or nSLWR line to perform the transfer. This model is configured by setting the [SETTING\\_FIFO\\_CONFIG](#) bits IFCFG (bits 0-1) to '11' to go to Slave FIFO Mode and ASYNC (bit 3) to '1' to make all transactions asynchronous.

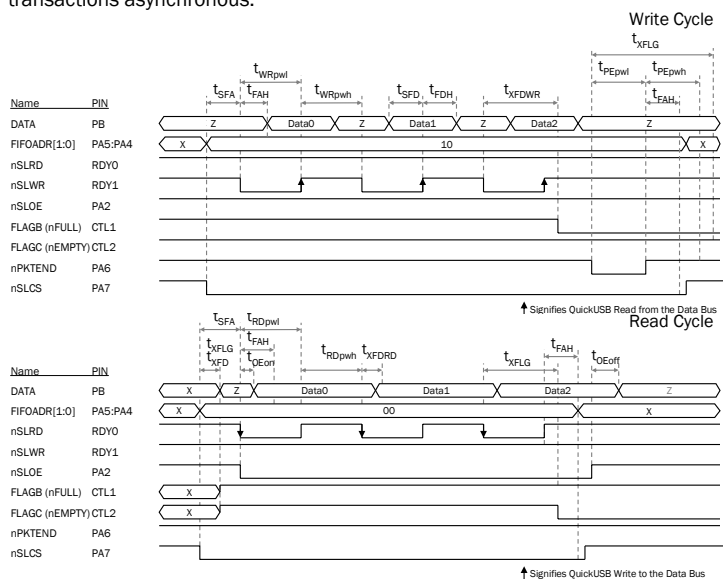

Figure 2 - Asynchronous Slave FIFO I/O Model Timing Diagrams

Parameter	Description	Min	Max	Unit
tRDpwl	SLRD Pulse Width Low	50		ns
tRDpwh	SLRD Pulse Width High	50		ns
tWRpwl	SLWR Pulse Width Low	50		ns
tWRpwh	SLWR Pulse Width High	70		ns
tSFD	SLWR to FIFO DATA Set-up Time	10		ns
tFDH	FIFO DATA to SLWR Hold Time	10		ns
tXFLG	SLRD to Flags Output Propagation Delay		70	ns
tXFDWR	SLWR to Flags Output Propagation Delay		70	ns
tXFDRD	SLRD to FIFO Data Output Propagation Delay		15	ns
tOEon	SLOE On to FIFO Data Valid		10.5	ns
tOEoff	SLOE Off to FIFO Data Hold		10.5	ns
tSFA	FIFOADR/nSLCS to SLRD/SLWR/PKTEND Set-up Time	10		ns
tFAH	SLRD/SLWR/PKTEND to FIFOADR/nSLCS Hold Time	10		ns
tPEpwl	PKTEND Pulse Width Low	50		ns
tPEpwh	PKTEND Pulse Width High	50		ns
tXFL	PKTEND to Flags Output Propagation Delay		115	ns

Table 5 - Asynchronous Slave FIFO Timing Parameters

# Designing Hardware for QuickUSB

## Slave245 I/O Model

The Slave245 I/O Model allows QuickUSB to duplicate the functionality of the FTDI245BM I/O waveforms with a speed increase of up to 10X. This I/O model is implemented in the QuickUSB firmware file 'quickusb-245 vX.XX.qusb' where X.XX is the firmware version number. The following QuickUSB I/O connections are used for 245BM targets:

QuickUSB Signal	245BM Signal
RDY0 (nSLRD) & PA2 (SLOE)	RD#
RDY1 (nSLWR) & PA5 (FIFOADR1)	WR
CTL2 (FLAGC)	RXF#
CTL1 (FLAGB)	TXE#
PB0	D0
PB1	D1
PB2	D2
PB3	D3
PB4	D4
PB5	D5
PB6	D6
PB7	D7

Figure 3 - QuickUSB to 245BM Connection Table

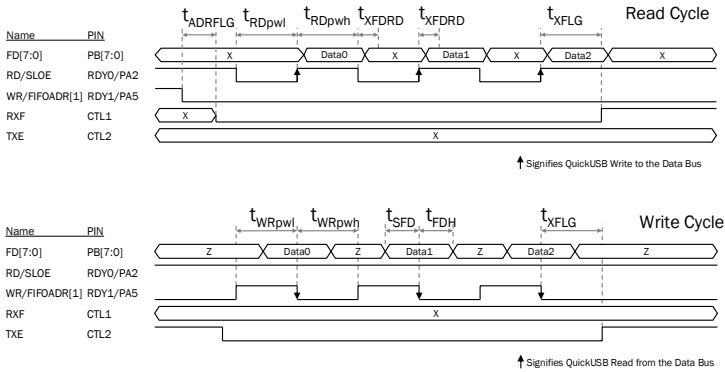

Figure 4 - Slave245 I/O Model Timing Diagrams

Parameter	Description	Min	Max	Unit
tRDpwl	SLRD Pulse Width Low	50		ns
tRDpwh	SLRD Pulse Width High	50		ns
tWRpwl	SLWR Pulse Width Low	50		ns
tWRpwh	SLWR Pulse Width High	70		ns
tSFD	SLWR to FIFO DATA Set-up Time	10		ns
tFDH	FIFO DATA to SLWR Hold Time	10		ns
tXFLG	SLRD/SLWR to Flags Output Propagation Delay		70	ns
tADRFLG	SLWR/FIFOADR[1] to Flags Output Propagation Delay		10.7	ns
tXFDRD	SLRD to FIFO Data Output Propagation Delay		15	ns

Figure 5 - Slave245 I/O Model Timing Parameters

## FPGA Configuration

The QuickUSB Plug-In module can configure SRAM-based FPGA devices over the USB. The configuration method that QuickUSB uses is based on the [SETTING\\_FPGATYPE](#) setting of the 'Settings' section of this document. Currently, two configuration schemes are supported: Altera Passive Serial and Xilinx Slave Serial.

The QuickUSB module uses 3.3V I/O, so make sure your device can handle 3.3V on the configuration pins. Then, connect the FPGA as shown in Table 6. You must be sure to add pull-up resistors required by the FPGA manufacturer. Refer to the FPGA manufacturer's documentation for the proper configuration connection pin out, signal level and device configuration mode. QuickUSB can transfer an unlimited number of configuration data blocks, so multiple daisy chained devices can be configured using QuickUSB.

QuickUSB Signal	Altera PS	Xilinx Slave Serial
DATA0	DATA0	DIN
DCLK	DCLK	CCLK
nCONFIG	nCONFIG	PROGRAM
nSTATUS	nSTATUS	INIT
CONF_DONE	CONF_DONE	DONE

*Table 6 - FPGA Configuration Signals*

## General-Purpose I/O Pins

The QuickUSB Module implements General Purpose I/O Pins on Ports A, B, C, D, and E when not using the alternate functions for those ports. Please see the ['QuickUSB Pin Definitions'](#) section of this user guide for information on the ports and which are being used for alternate functions.

### RS-232

The QuickUSB Module's RS-232 Ports provide standard asynchronous, full-duplex communications. The RS-232 ports operate with no parity, eight data bits, and one stop bit (N81). RS-232 data is received using interrupt-driven receive routines in the module. Both ports operate at the same baud rate.

### I2C

The QuickUSB I<sup>2</sup>C-compatible port is a master-only bus controller that can operate in Standard Mode (100kHz) or Fast Mode (400kHz) with 7-bit addressing. The bus speed is selectable using Bit 0 of SETTING\_I2CTL. Address 81 (decimal) is reserved. The R/W bit is automatically inserted, so it does not need to be included in the address. The address is automatically shifted to accommodate the R/W bit.

# Designing Hardware for QuickUSB

## SPI

The QuickUSB module implements a 'soft' SPI port using pins on port E and optionally port A. These routines support from 1 to 10 devices with individual slave select lines for each device. The slave select lines are active low and are shown in [Table 7 - QuickUSB Pin Definitions](#). The signals are MOSI, SCK, MISO and nSS0-9. By default, data is shifted in and out MSbit to LSbit. The bit shift order can be configured by changing Bit 0 of the [SETTINGS.SPICONFIG](#) setting. The SPI bus runs at approximately 500Kbps.

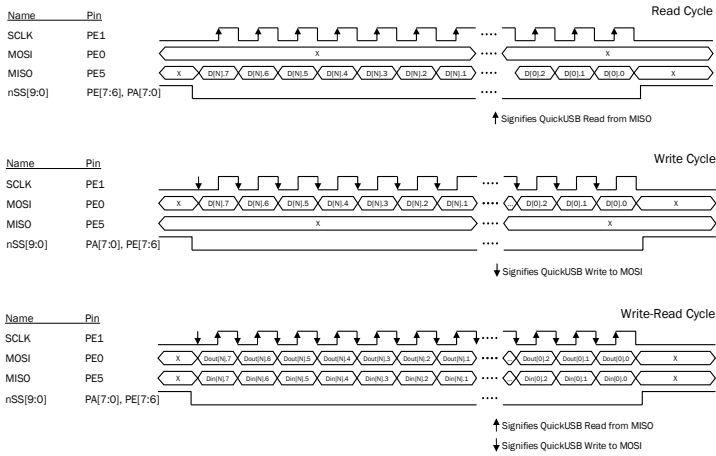

Figure 6 - SPI Timing Diagrams

If using any of the slave select signals on Port A (nSS2-9), Port A will convert to the alternate slave select functionality for the entire port. Please ensure you do not use Port A for General Purpose I/O if using the slave select 2-9 (nSS2-9) signals.

If using any of the slave select signals on Port E (nSS0-1) PE6 and PE7 will convert to the alternate slave select functionality for the entire port. Please ensure you do not use PE6 or PE7 for General Purpose I/O if using the nSS0-nSS1 signals.

## QuickUSB Pin Definitions

FX2128 Pin	QUSB2 Pin	Name	Dir	Desc	Function
N/A	76	SW_EN	Output	VBUS Switch Enable	SW_EN is high when the QuickUSB Module has successfully enumerated and power can be drawn from VBUS. Used to control the VBUS switch on the QuickUSB Module.
82	3	PA0 / nSS2 / nINT0	I/O	Port A, Bit 0	Multifunction Pin <b>PA0</b> (default) is a bi-directional general purpose I/O pin. <b>nSS2</b> is the SPI slave select signal for Address 2. Automatically switches functionality when using the SPI commands. <i>Note: If using nSS2-nSS9, all of Port A is converted to slave select functionality, so ensure that Port A is not used for GPIO if using nSS2-nSS9.</i> <b>nINT0</b> is an active low interrupt input signal. This function is currently unused.
83	5	PA1 / nSS3 / nINT1	I/O	Port A, Bit 1	Multifunction Pin <b>PA1</b> (default) is a bi-directional general purpose I/O pin. <b>nSS3</b> is the SPI slave select signal for Address 3. Automatically switches functionality when using the SPI commands. <i>See Note for nSS2.</i> <b>nINT1</b> is an active low interrupt input signal. This function is currently unused.
84	7	PA2 / nSS4 / nSLOE	I/O	Port A, Bit 2	Multifunction Pin whose function is selected by SETTING_FIFO_CONFIG[1:0]: <b>PA2</b> (default) is a bi-directional general purpose I/O pin. Enabled when SETTING_FIFO_CONFIG[1:0] = '00' or '10' <b>nSS4</b> is the SPI slave select signal for Address 4. <i>See Note for nSS2.</i> <b>nSLOE</b> is an input-only active low output enable when operating in slave mode. Enabled when
85	9	PA3 / nSS5	I/O	Port A, Bit 3	Multifunction Pin <b>PA3</b> (default) is a bi-directional general purpose I/O pin. <b>nSS5</b> is the SPI slave select signal for Address 5. <i>See Note for nSS2.</i>

## Designing Hardware for QuickUSB

FX2128 Pin	QUSB2 Pin	Name	Dir	Desc	Function
89	11	PA4 / nSS6/ FIFOADR0	I/O	Port A, Bit 4	Multifunction Pin whose function is selected by SETTING_FIFO_CONFIG[1:0]: <b>PA4</b> (default) is a bi-directional general purpose I/O pin. Enabled when SETTING_FIFO_CONFIG[1:0]: = '00' or '10' <b>nSS6</b> is the SPI slave select signal for Address 6. <i>See Note for nSS2.</i> <b>FIFOADR0</b> is an input-only address select for slave devices when operating in slave mode. Enabled when SETTING_FIFO_CONFIG[1:0]: = '11'. <i>See Note for SLOE.</i>
90	13	PA5 / nSS7/ FIFOADR1	I/O	Port A, Bit 5	Multifunction Pin whose function is selected by SETTING_FIFO_CONFIG[1:0]: <b>PA5</b> (default) is a bi-directional general purpose I/O pin. Enabled when SETTING_FIFO_CONFIG[1:0]: = '00' or '10' <b>nSS7</b> is the SPI slave select signal for Address 7. <i>See Note for nSS2.</i> <b>FIFOADR1</b> is an input-only address select for slave devices when operating in slave mode. Enabled when SETTING_FIFO_CONFIG[1:0]: = '11'. <i>See Note for SLOE.</i>
91	15	PA6 / nSS8 /nPKTEND	I/O	Port A, Bit 6	Multifunction Pin whose function is selected by SETTING_FIFO_CONFIG[1:0]: <b>PA6</b> (default) is a bi-directional general purpose I/O pin. Enabled when SETTING_FIFO_CONFIG[1:0]: = '00' or '10' <b>nSS8</b> is the SPI slave select signal for Address 8. <i>See Note for nSS2.</i> <b>nPKTEND</b> is an input-only active low signal used to commit the FIFO packet data for slave devices when operating in slave mode. Enabled when SETTING_FIFO_CONFIG[1:0]: = '11'. <i>See Note for SLOE.</i>

## Designing Hardware for QuickUSB

FX2128 Pin	QUSB2 Pin	Name	Dir	Desc	Function
92	17	PA7 / nSS9 / FLAGD / nSLCS	I/O	Port A, Bit 7	Multifunction Pin whose function is selected by SETTING_FIFO_CONFIG[1:0]: <b>PA7</b> (default) is a bi-directional general purpose I/O pin. Enabled when SETTING_FIFO_CONFIG[1:0] = '00' or '10' <b>nSS9</b> is the SPI slave select signal for Address 9. <i>See Note for nSS2.</i> <b>nSLCS</b> is an input-only active low chip select for slave devices. Enabled when SETTING_FIFO_CONFIG[1:0] = '11' and SETTING_PORTACCFG = '0x80'. <i>See Note for SLOE.</i> <b>FLAGD</b> : EP2 Programmable Flag status. Enabled when SETTING_FIFO_CONFIG[1:0] = '11' and SETTING_PORTACCFG = '0x40'. <i>See Note for SLOE.</i>
44	21	PB0 / FD0	I/O	Port B, Bit 0	Multifunction Pin whose function is selected by SETTING_FIFO_CONFIG[1:0]: <b>PB0</b> is a bi-directional general purpose I/O pin. Enabled when SETTING_FIFO_CONFIG[1:0] = '00' <b>FD0</b> (default) is the bi-directional GPIF data bus low byte. Enabled when SETTING_FIFO_CONFIG[1:0] = '10'
45	23	PB1 / FD1	I/O	Port B, Bit 1	Multifunction Pin whose function is selected by SETTING_FIFO_CONFIG[1:0]: <b>PB1</b> is a bi-directional general purpose I/O port. Enabled when SETTING_FIFO_CONFIG[1:0] = '00' <b>FD1</b> (default) is the bi-directional GPIF data bus low byte. Enabled when SETTING_FIFO_CONFIG[1:0] = '10'
46	25	PB2 / FD2	I/O	Port B, Bit 2	Multifunction Pin whose function is selected by SETTING_FIFO_CONFIG[1:0]: <b>PB2</b> is a bi-directional general purpose I/O port. Enabled when SETTING_FIFO_CONFIG[1:0] = '00' <b>FD2</b> (default) is the bi-directional GPIF data bus low byte. Enabled when SETTING_FIFO_CONFIG[1:0] = '10'
47	27	PB3 / FD3	I/O	Port B, Bit 3	Multifunction Pin whose function is selected by SETTING_FIFO_CONFIG[1:0]: <b>PB3</b> is a bi-directional general purpose I/O port. Enabled when SETTING_FIFO_CONFIG[1:0] = '00' <b>FD3</b> (default) is the bi-directional GPIF data bus low byte. Enabled when SETTING_FIFO_CONFIG[1:0] = '10'

## Designing Hardware for QuickUSB

FX2128 Pin	QUSB2 Pin	Name	Dir	Desc	Function
54	29	PB4 / FD4	I/O	Port B, Bit 4	Multifunction Pin whose function is selected by SETTING_FIFO_CONFIG[1:0]: <b>PB4</b> is a bi-directional general purpose I/O port. Enabled when SETTING_FIFO_CONFIG[1:0] = '00' <b>FD4</b> (default) is the bi-directional GPIF data bus low byte. Enabled when SETTING_FIFO_CONFIG[1:0] = '10'
55	31	PB5 / FD5	I/O	Port B, Bit 5	Multifunction Pin whose function is selected by SETTING_FIFO_CONFIG[1:0]: <b>PB5</b> is a bi-directional general purpose I/O port. Enabled when SETTING_FIFO_CONFIG[1:0] = '00' <b>FD5</b> (default) is the bi-directional GPIF data bus low byte. Enabled when SETTING_FIFO_CONFIG[1:0] = '10'
56	33	PB6 / FD6	I/O	Port B, Bit 6	Multifunction Pin whose function is selected by SETTING_FIFO_CONFIG[1:0]: <b>PB6</b> is a bi-directional general purpose I/O port. Enabled when SETTING_FIFO_CONFIG[1:0] = '00' <b>FD6</b> (default) is the bi-directional GPIF data bus low byte. Enabled when SETTING_FIFO_CONFIG[1:0] = '10'
57	35	PB7 / FD7	I/O	Port B, Bit 7	Multifunction Pin whose function is selected by SETTING_FIFO_CONFIG[1:0]: <b>PB7</b> is a bi-directional general purpose I/O port. Enabled when SETTING_FIFO_CONFIG[1:0] = '00' <b>FD7</b> (default) is the bi-directional GPIF data bus low byte. Enabled when SETTING_FIFO_CONFIG[1:0] = '10'
72	39	PC0 / GPIFADR0	I/O	Port C, Bit 0	Multifunction Pin whose function is selected by SETTING_FIFO_CONFIG[1:0]: <b>PC0</b> is a bi-directional general purpose I/O port. Enabled when SETTING_FIFO_CONFIG[1:0] = '00' <b>GPIFADR0</b> (default) is a GPIF address output pin. Enabled when SETTING_FIFO_CONFIG[1:0] = '10'
73	41	PC1 / GPIFADR1	I/O	Port C, Bit 1	Multifunction Pin whose function is selected by SETTING_FIFO_CONFIG[1:0]: <b>PC1</b> is a bi-directional general purpose I/O port. Enabled when SETTING_FIFO_CONFIG[1:0] = '00' <b>GPIFADR1</b> (default) is a GPIF address output pin. Enabled when SETTING_FIFO_CONFIG[1:0] = '10'

## Designing Hardware for QuickUSB

FX2128 Pin	QUSB2 Pin	Name	Dir	Desc	Function
74	43	PC2 / GPIFADR2	I/O	Port C, Bit 2	Multifunction Pin whose function is selected by SETTING_FIFO_CONFIG[1:0]: PC2 is a bi-directional general purpose I/O port. Enabled when SETTING_FIFO_CONFIG[1:0] = '00' GPIFADR2 (default) is a GPIF address output pin. Enabled when SETTING_FIFO_CONFIG[1:0] = '10'
75	45	PC3 / GPIFADR3	I/O	Port C, Bit 3	Multifunction Pin whose function is selected by SETTING_FIFO_CONFIG[1:0]: PC3 is a bi-directional general purpose I/O port. Enabled when SETTING_FIFO_CONFIG[1:0] = '00' GPIFADR3 (default) is a GPIF address output pin. Enabled when SETTING_FIFO_CONFIG[1:0] = '10'
76	47	PC4 / GPIFADR4	I/O	Port C, Bit 4	Multifunction Pin whose function is selected by SETTING_FIFO_CONFIG[1:0]: PC4 is a bi-directional general purpose I/O port. Enabled when SETTING_FIFO_CONFIG[1:0] = '00' GPIFADR4 (default) is a GPIF address output pin. Enabled when SETTING_FIFO_CONFIG[1:0] = '10'
77	49	PC5 / GPIFADR5	I/O	Port C, Bit 5	Multifunction Pin whose function is selected by SETTING_FIFO_CONFIG[1:0]: PC5 is a bi-directional general purpose I/O port. Enabled when SETTING_FIFO_CONFIG[1:0] = '00' GPIFADR5 (default) is a GPIF address output pin. Enabled when SETTING_FIFO_CONFIG[1:0] = '10'
78	51	PC6 / GPIFADR6	I/O	Port C, Bit 6	Multifunction Pin whose function is selected by SETTING_FIFO_CONFIG[1:0]: PC6 is a bi-directional general purpose I/O port. Enabled when SETTING_FIFO_CONFIG[1:0] = '00' GPIFADR6 (default) is a GPIF address output pin. Enabled when SETTING_FIFO_CONFIG[1:0] = '10'
79	53	PC7 / GPIFADR7	I/O	Port C, Bit 7	Multifunction Pin whose function is selected by SETTING_FIFO_CONFIG[1:0]: PC7 is a bi-directional general purpose I/O port. Enabled when SETTING_FIFO_CONFIG[1:0] = '00' GPIFADR7 (default) is a GPIF address output pin. Enabled when SETTING_FIFO_CONFIG[1:0] = '10'

## Designing Hardware for QuickUSB

FX2128 Pin	QUSB2 Pin	Name	Dir	Desc	Function
102	57	PD0 / FD8	I/O	Port D, Bit 0	Multifunction Pin whose function is selected by SETTING_FIFO_CONFIG[1:0]: <b>PD0</b> is a bi-directional general purpose I/O port. Enabled when SETTING_FIFO_CONFIG[1:0] = '00' or when SETTING_WORDWIDE = '0' <b>FD8</b> (default) is the bi-directional GPIF data bus. Enabled when SETTING_FIFO_CONFIG[1:0] = '10' and when SETTING_WORDWIDE = '1'
103	59	PD1 / FD9	I/O	Port D, Bit 1	Multifunction Pin whose function is selected by SETTING_FIFO_CONFIG[1:0]: <b>PD1</b> is a bi-directional general purpose I/O port. Enabled when SETTING_FIFO_CONFIG[1:0] = '00' or when SETTING_WORDWIDE = '0' <b>FD9</b> (default) is the bi-directional GPIF data bus. Enabled when SETTING_FIFO_CONFIG[1:0] = '10' and when SETTING_WORDWIDE = '1'
104	61	PD2 / FD10	I/O	Port D, Bit 2	Multifunction Pin whose function is selected by SETTING_FIFO_CONFIG[1:0]: <b>PD2</b> is a bi-directional general purpose I/O port. Enabled when SETTING_FIFO_CONFIG[1:0] = '00' or when SETTING_WORDWIDE = '0' <b>FD10</b> (default) is the bi-directional GPIF data bus. Enabled when SETTING_FIFO_CONFIG[1:0] = '10' and when SETTING_WORDWIDE = '1'
105	63	PD3 / FD11	I/O	Port D, Bit 3	Multifunction Pin whose function is selected by SETTING_FIFO_CONFIG[1:0]: <b>PD3</b> is a bi-directional general purpose I/O port. Enabled when SETTING_FIFO_CONFIG[1:0] = '00' or when SETTING_WORDWIDE = '0' <b>FD11</b> (default) is the bi-directional GPIF data bus. Enabled when SETTING_FIFO_CONFIG[1:0] = '10' and when SETTING_WORDWIDE = '1'

## Designing Hardware for QuickUSB

FX2128 Pin	QUSB2 Pin	Name	Dir	Desc	Function
121	65	PD4 / FD12	I/O	Port D, Bit 4	Multifunction Pin whose function is selected by SETTING_FIFO_CONFIG[1:0]: PD4 is a bi-directional general purpose I/O port. Enabled when SETTING_FIFO_CONFIG[1:0] = '00' or when SETTING_WORDWIDE = '0' FD12 (default) is the bi-directional GPIF data bus. Enabled when SETTING_FIFO_CONFIG[1:0] = '10' and when SETTING_WORDWIDE = '1'
122	67	PD5 / FD13	I/O	Port D, Bit 5	Multifunction Pin whose function is selected by SETTING_FIFO_CONFIG[1:0]: PD5 is a bi-directional general purpose I/O port. Enabled when SETTING_FIFO_CONFIG[1:0] = '00' or when SETTING_WORDWIDE = '0' FD13 is the bi-directional GPIF data bus. Enabled when SETTING_FIFO_CONFIG[1:0] = '10' and when SETTING_WORDWIDE = '1'
123	69	PD6 / FD14	I/O	Port D, Bit 6	Multifunction Pin whose function is selected by SETTING_FIFO_CONFIG[1:0]: PD6 is a bi-directional general purpose I/O port. Enabled when SETTING_FIFO_CONFIG[1:0] = '00' or when SETTING_WORDWIDE = '0' FD14 is the bi-directional GPIF data bus. Enabled when SETTING_FIFO_CONFIG[1:0] = '10' and when SETTING_WORDWIDE = '1'
124	71	PD7 / FD15	I/O	Port D, Bit 7	Multifunction Pin whose function is selected by SETTING_FIFO_CONFIG[1:0]: PD7 is a bi-directional general purpose I/O port. Enabled when SETTING_FIFO_CONFIG[1:0] = '00' or when SETTING_WORDWIDE = '0' FD15 (default) is the bi-directional GPIF data bus. Enabled when SETTING_FIFO_CONFIG[1:0] = '10' and when SETTING_WORDWIDE = '1'

## Designing Hardware for QuickUSB

FX2128 Pin	QUSB2 Pin	Name	Dir	Desc	Function
108	58	PE0 / DATA0 / MOSI	I/O	Port E, Bit 0	<p>Multifunction Pin  <b>PE0</b> (default) is a bi-directional general purpose I/O port. Enabled when SETTING_FIFO_CONFIG[1:0] = '00', '10', or '11'</p> <p><b>DATA0</b> is the data output signal for serial FPGA configuration. Automatically switches functionality when using the FPGA configuration commands.</p> <p><b>MOSI</b> is the Master-Out Slave-In data signal for the SPI port. Automatically switches functionality when using the SPI commands.</p>
109	60	PE1 / DCLK / SCK	I/O	Port E, Bit 1	<p>Multifunction Pin  <b>PE1</b> (default) is a bi-directional general purpose I/O port. Enabled when SETTING_FIFO_CONFIG[1:0] = '00', '10', or '11'</p> <p><b>DCLK</b> is the clock output signal for serial FPGA configuration. Automatically switches functionality when using the FPGA configuration commands.</p> <p><b>SCLK</b> is the clock output signal for the SPI port. Automatically switches functionality when using the SPI commands.</p>
110	62	PE2 / nCE	I/O	Port E, Bit 2	<p>Multifunction Pin  <b>PE2</b> is a bi-directional general purpose I/O port. Enabled when SETTING_FIFO_CONFIG[1:0] = '00', '10', or '11'</p> <p><b>nCE</b> is available for use as a Chip Enable signal for SPI commands. It is controlled using the normal GPIO function calls.</p>
111	64	PE3 / nCONFIG	I/O	Port E, Bit 3	<p>Multifunction Pin  <b>PE3</b> (default) is a bi-directional general purpose I/O port. Enabled when SETTING_FIFO_CONFIG[1:0] = '00', '10', or '11'</p> <p><b>nCONFIG</b> is the Configure/Program output signal for serial FPGA configuration. Automatically switches functionality when using the FPGA configuration commands.</p>
112	66	PE4 / nSTATUS	I/O	Port E, Bit 4	<p>Multifunction Pin  <b>PE4</b> (default) is a bi-directional general purpose I/O port. Enabled when SETTING_FIFO_CONFIG[1:0] = '00', '10', or '11'</p> <p><b>nSTATUS</b> is the Status input signal for serial FPGA configuration. Automatically switches functionality when using the FPGA configuration commands.</p>

## Designing Hardware for QuickUSB

FX2128 Pin	QUSB2 Pin	Name	Dir	Desc	Function
113	68	PE5 / CONF_DONE / MISO	I/O	Port E, Bit 5	<p>Multifunction Pin  <b>PE5</b> (default) is a bi-directional general purpose I/O port. Enabled when SETTING_FIFO_CONFIG[1:0] = '00', '10', or '11'  <b>CONF_DONE</b> is the Done output signal for serial FPGA configuration. Automatically switches functionality when using the FPGA configuration commands.  <b>MISO</b> is the Master-In Slave-Out data signal for the SPI port. Automatically switches functionality when using the SPI commands.</p>
114	70	PE6 / nSS0	I/O	Port E, Bit 6	<p>Multifunction Pin  <b>PE6</b> (default) is a bi-directional general purpose I/O port. Enabled when SETTING_FIFO_CONFIG[1:0] = '00', '10', or '11'  <b>nSS0</b> is the active low slave select signal for Address 0 of the SPI port. Automatically switches functionality when using the SPI commands.  <i>Note: If using nSS0-nSS1, PE6 and PE7 convert to SPI slave select functionality, so ensure that PE6 and PE7 are not used for GPIO if using SPI nSS0-nSS1.</i></p>
115	72	PE7 / GPIFADR8 / nSS1	I/O	Port E, Bit 7	<p>Multifunction Pin  <b>PE7</b> is a bi-directional general purpose I/O port. Enabled when SETTING_FIFO_CONFIG[1:0] = '00', or '11'  <b>GPIFADR8</b> (default) is a GPIF address output pin. Enabled when SETTING_FIFO_CONFIG[1:0] = '10'  <b>nSS1</b> is the active low slave select signal for Address 1 of the SPI port. Automatically switches functionality when using the SPI commands. <i>See Note for nSS0.</i></p>
36	73	SCL	Output	Clock for I2C interface	Clock for I2C Interface. <i>Connect to VCC with a 2.2K resistor, even if no I2C peripheral is attached.</i> Connected to VCC with 2.2K resistor on QuickUSB Module.
37	75	SDA	OD	Data for I2C interface	Data for I2C Interface. <i>Connect to VCC with a 2.2K resistor, even if no I2C peripheral is attached.</i> Connected to VCC with 2.2K resistor on QuickUSB Module.
29	77	T0	Input	Input for Timer0	Active High Input to Timer0. Not needed for general operation.
30	78	T1	Input	Input for Timer1	Active High input to Timer1. Not needed for general operation.
31	N/A	T2	Input	Input for Timer2	Active High input to Timer2. Connected to VCC through 2.2k resistor on QuickUSB Module.

## Designing Hardware for QuickUSB

FX2128 Pin	QUSB2 Pin	Name	Dir	Desc	Function
99	4	RESET_B	OD	FX2 reset, Active low.	Active Low Reset. Resets the entire chip. Connected to VCC through a 10k resistor on QuickUSB Module.
1	6	CLKOUT	Output	48MHz CPU Clock	A 12, 24, or 48MHz output clock, phase locked to the 24MHz input clock. CLKOUT settings can be configured through SETTING_CPUCONFIG[4:1]. Default frequency is 48MHz.
32	8	IFCLK	Output	48MHz GPIO Clock	GPIF Interface Clock. Used to synchronously clock data in or out of the on-chip FIFOs. Also used as a timing reference for all control, data, and address signals on the GPIF. IFCLK settings can be configured through SETTING_FIFO_CONFIG[7:4].
28	10	INT4	Input	INT4 Interrupt Request	FX2 internal interrupt request input signal. Active High, Edge Sensitive. This function is currently unused.
106	76	INT5_B	Input	INT5 Interrupt Request	FX2 internal interrupt request input signal. Active Low, Edge Sensitive. This function is currently unused.
N/A	12	RXD_0	Input	Serial Port 0 RxD	Serial Port 0 RxD <i>Note: If U1 is populated with a Linear Tech part, QuickUSB Module uses EIA/TIA 564 Levels. If U1 is populated with a TI part, QuickUSB Module uses RS-232 levels.</i>
N/A	14	TXD_0	Output	Serial Port 0 TxD	Serial Port 0 TxD <i>See Note for RXD_0</i>
N/A	16	TXD_1	Output	Serial Port 1 TxD	Serial Port 1 TxD <i>See Note for RXD_0</i>
N/A	18	RXD_1	Input	Serial Port 1 RxD	Serial Port 1 RxD <i>See Note for RXD_0</i>
69	22	CTL0 / CMD_DATA /FLAGA	Output	GPIF Control Output 0	Multifunction Pin whose function is selected by SETTING_FIFO_CONFIG[1:0]: <b>CTL0</b> (default) is a GPIF output signal whose function (CMD_DATA) is waveform specific. Enabled when SETTING_FIFO_CONFIG[1:0] = '10'. <b>CMD_DATA</b> is the active high Command Enable output signal for the GPIF. Implemented in the Simple, FIFO Handshake, Full Handshake, and Block Handshake I/O Models. Enabled when SETTING_FIFO_CONFIG[1:0] = '10'. <b>FLAGA</b> is the Slave FIFO Half-Full Flag. Gives half-full status of the FIFO selected by FIFOADR[1:0] in slave mode. Output only, active low. Enabled when SETTING_FIFO_CONFIG[1:0] = '11'

## Designing Hardware for QuickUSB

FX2128 Pin	QUSB2 Pin	Name	Dir	Desc	Function
70	24	CTL1 / REN / FLAGB / nFULL	Output	GPIF Control Output 1	Multifunction Pin whose function is selected by SETTING_FIFO_CONFIG[1:0]: <b>CTL1</b> (default) is a GPIF output signal whose function (REN) is waveform specific. Enabled when SETTING_FIFO_CONFIG[1:0] = '10'. <b>REN</b> is the active high Read Enable output signal for the GPIF. Implemented in the Simple, FIFO Handshake, Full Handshake, and Block Handshake I/O Models. Enabled when SETTING_FIFO_CONFIG[1:0] = '10'. <b>FLAGB / nFULL</b> is the Slave FIFO Full Flag. Gives Full status of the FIFO selected by FIFOADR[1:0] in slave mode. Output only, active low. Enabled when SETTING_FIFO_CONFIG[1:0] = '11'
71	26	CTL2 / WEN / FLAGC / nEMPTY	Output	GPIF Control Output 2	Multifunction Pin whose function is selected by SETTING_FIFO_CONFIG[1:0]: <b>CTL2</b> (default) is a GPIF output signal whose function (WEN) is waveform specific. Enabled when SETTING_FIFO_CONFIG[1:0] = '10'. <b>WEN</b> is the active high Write Enable output signal for the GPIF. Implemented in the Simple, FIFO Handshake, Full Handshake, and Block Handshake I/O Models. Enabled when SETTING_FIFO_CONFIG[1:0] = '10'. <b>FLAGC / nEMPTY</b> is the Slave FIFO Empty Flag. Gives Empty status of the FIFO selected by FIFOADR[1:0] in slave mode. Output only, active low. Enabled when SETTING_FIFO_CONFIG[1:0] = '11'
66	28	CTL3 / nREN	Output	GPIF Control Output 3	<b>CTL3</b> is a GPIF output signal whose function (nREN) is waveform specific. Enabled when SETTING_FIFO_CONFIG[1:0] = '10'. <b>nREN</b> is the active low Read Enable output signal for the GPIF. Implemented in the Simple, FIFO Handshake, Full Handshake, and Block Handshake I/O Models. Enabled when SETTING_FIFO_CONFIG[1:0] = '10'.

## Designing Hardware for QuickUSB

FX2128 Pin	QUSB2 Pin	Name	Dir	Desc	Function
67	30	CTL4 / nWEN	Output	GPIF Control Output 4	CTL4 is a GPIF output signal whose function (nWEN) is waveform specific. Enabled when SETTING_FIFO_CONFIG[1:0] = '10'. nWEN is the active low Write Enable output signal for the GPIF. Implemented in the Simple, FIFO Handshake, Full Handshake, and Block Handshake I/O Models. Enabled when SETTING_FIFO_CONFIG[1:0] = '10'.
98	32	CTL5 / nOE / RDYTEST	Output	GPIF Control Output 5	CTL5 is a GPIF output signal whose function (nOE or RDYTEST) is waveform specific. Enabled when SETTING_FIFO_CONFIG[1:0] = '10'. nOE is the active low Output Enable output signal for the GPIF. Implemented in the Simple, FIFO Handshake, and Block Handshake I/O Models. Enabled when SETTING_FIFO_CONFIG[1:0] = '10'. RDYTEST is the Ready Test output signal for the Full Handshake I/O Model. RDYTEST outputs the correct handshake waveform for the READY line, so it can be connected to READY to test the Full Handshake functionality. Implemented in the Full Handshake I/O Model. Enabled when SETTING_FIFO_CONFIG[1:0] = '10'.
51	34	RXD0	Input	Serial Port 0 TTL RxD	RXD0 is the receive signal for the 8051 UART0. Active High, Input only. Do not use if U1 is populated on the QuickUSB Module.
50	36	TXD0	Output	Serial Port 0 TTL TxD	TXD0 is the transmit signal for the 8051 UART0. Active High, Output only. Do not use if U1 is populated on the QuickUSB Module.
53	52	RXD1	Input	Serial Port 1 TTL RxD	RXD1 is the receive signal for the 8051 UART1. Active High, Input only. Do not use if U1 is populated on the QuickUSB Module.
52	54	TXD1	Output	Serial Port 1 TTL TxD	TXD1 is the transmit signal for the 8051 UART1. Active High, Output only. Do not use if U1 is populated on the QuickUSB Module.

## Designing Hardware for QuickUSB

FX2128 Pin	QUSB2 Pin	Name	Dir	Desc	Function
4	40	RDY0 / nEMPTY / READY / nSLRD	Input	GPIF input signal 0	Multifunction Pin whose function is selected by SETTING_FIFO_CONFIG[1:0]: <b>RDY0</b> (default) is a GPIF input signal whose function (nEMPTY or READY) is waveform specific. Enabled when SETTING_FIFO_CONFIG[1:0] = '10' <b>nEMPTY</b> is an active low input that checks the status of the EMPTY flag of a connected FIFO. Implemented in the FIFO Handshake and Block Handshake I/O Models. Enabled when SETTING_FIFO_CONFIG[1:0] = '10' <b>READY</b> is an input that checks the status of the READY flag of a slave device. Implemented in the Full Handshake I/O Model. Enabled when SETTING_FIFO_CONFIG[1:0] = '10' <b>nSLRD</b> is the Slave Read Strobe. Input only, active low. Enabled when SETTING_FIFO_CONFIG[1:0] = '11'
5	42	RDY1 / nFULL / nSLWR	Input	GPIF input signal 1	Multifunction Pin whose function is selected by SETTING_FIFO_CONFIG[1:0]: <b>RDY1</b> (default) is a GPIF input whose function (nFULL) is waveform specific. Enabled when SETTING_FIFO_CONFIG[1:0] = '10' <b>nFULL</b> is an active low input that checks the status of the FULL flag of a connected FIFO. Implemented in the FIFO Handshake and Block Handshake waveforms. Enabled when SETTING_FIFO_CONFIG[1:0] = '10' <b>nSLWR</b> is the Slave Write Strobe. Input only, active low. Enabled when SETTING_FIFO_CONFIG[1:0] = '11'
6	44	RDY2	Input	GPIF input signal 2	<b>RDY2</b> is a GPIF input signal. Enabled when SETTING_FIFO_CONFIG[1:0] = '10'. Not currently used by QuickUSB.
7	46	RDY3	Input	GPIF input signal 3	<b>RDY3</b> is a GPIF input signal. Enabled when SETTING_FIFO_CONFIG[1:0] = '10'. Not currently used by QuickUSB.
8	48	RDY4	Input	GPIF input signal 4	<b>RDY4</b> is a GPIF input signal. Enabled when SETTING_FIFO_CONFIG[1:0] = '10'. Not currently used by QuickUSB.
9	50	RDY5	Input	GPIF input signal 5	<b>RDY5</b> is a GPIF input signal. Enabled when SETTING_FIFO_CONFIG[1:0] = '10'. Not currently used by QuickUSB.

## Designing Hardware for QuickUSB

FX2128 Pin	QUSB2 Pin	Name	Dir	Desc	Function
101	74	WAKEUP_B	Input	USB Wakeup	USB Wakeup. Asserting pin brings FX2 out of suspend mode. Active Low. Not used, connected to VCC through a 10k resistor on QuickUSB Module.
19	N/A	DMINUS	I/O	USB D-Signal	Connect to the USB D- Signal
18	N/A	DPLUS	I/O	USB D+ Signal	Connect to the USB D+ Signal
94	N/A	A0	Output	8051 Address Bus	8051 Address Bus. Driven at all times. Reflects internal address when 8051 is addressing RAM. Not connected on QuickUSB Module.
95	N/A	A1	Output		
96	N/A	A2	Output		
97	N/A	A3	Output		
117	N/A	A4	Output		
118	N/A	A5	Output		
119	N/A	A6	Output		
120	N/A	A7	Output		
126	N/A	A8	Output		
127	N/A	A9	Output		
128	N/A	A10	Output		
21	N/A	A11	Output		
22	N/A	A12	Output		
23	N/A	A13	Output		
24	N/A	A14	Output		
25	N/A	A15	Output		
59	N/A	D0	I/O	8051 Data Bus	8051 Data Bus. Bi-directional bus used for external 8051 program and data memory. High Impedance when inactive. Active only for external bus accesses. Driven low in suspend. Not connected on QuickUSB Module.
60	N/A	D1	I/O		
61	N/A	D2	I/O		
62	N/A	D3	I/O		
63	N/A	D4	I/O		
86	N/A	D5	I/O		
87	N/A	D6	I/O		
88	N/A	D7	I/O		
39	N/A	PSEN#	Output	Program Store Enable	Indicates an 8051 code fetch from external memory. Active low.
34	N/A	BKPT	Output	Breakpoint	Used as SW_EN on the QuickUSB module to control the onboard VBUS switch.
35	N/A	EA	Input	External Access	Determines where the 8051 fetches code from RAM. If EA=0, 8051 fetches from internal Ram. If EA=1, 8051 fetches from external RAM. Tied to GND through 10k Resistor on QuickUSB Module.
12	N/A	XTALIN	Input	Crystal Input	Connect to 24MHz parallel resonant, fundamental mode crystal and connect the parallel load capacitor to GND.
11	N/A	XTALOUT	Output	Crystal Output	Connect to 24MHz parallel resonant, fundamental mode crystal and connect the parallel load capacitor to GND.
42	N/A	CS#	Output	External Memory Chip Select	External Memory Chip Select. Active Low. Not connected on QuickUSB Module

## Designing Hardware for QuickUSB

FX2128 Pin	QUSB2 Pin	Name	Dir	Desc	Function
41	N/A	WR#	Output	External Memory Write Strobe	External Memory Write Strobe. Active Low. Not connected on QuickUSB Module
40	N/A	RD#	Output	External Memory Read Strobe	External Memory Read Strobe. Active Low. Not connected on QuickUSB Module
38	N/A	OE#	Output	External Memory Output Enable	External Memory Output Enable. Active Low. Not connected on QuickUSB Module
33	N/A	Reserved	Input	Reserved	Reserved. Connect to Ground
2	N/A	VCC	Power	VCC	VCC Connect VCC to 3.3V Power Source
26	N/A	VCC	Power	VCC	VCC Connect VCC to 3.3V Power Source
43	N/A	VCC	Power	VCC	VCC Connect VCC to 3.3V Power Source
48	N/A	VCC	Power	VCC	VCC Connect VCC to 3.3V Power Source
64	N/A	VCC	Power	VCC	VCC Connect VCC to 3.3V Power Source
68	N/A	VCC	Power	VCC	VCC Connect VCC to 3.3V Power Source
81	N/A	VCC	Power	VCC	VCC Connect VCC to 3.3V Power Source
100	N/A	VCC	Power	VCC	VCC Connect VCC to 3.3V Power Source
107	N/A	VCC	Power	VCC	VCC Connect VCC to 3.3V Power Source
10	N/A	AVCC	N/A	Analog VCC	<b>ANALOG VCC</b> connect to 3.3V power source. Provides power to the analog side of the FX2
17	N/A	AVCC	N/A	Analog VCC	<b>ANALOG VCC</b> connect to 3.3V power source. Provides power to the analog side of the FX2
13	N/A	AGND	N/A	Analog GND	<b>ANALOG GND</b> Connect to ground with the shortest lead possible
20	N/A	AGND	N/A	Analog GND	<b>ANALOG GND</b> Connect to ground with the shortest lead possible
N/A	2	+5V	N/A	Unregulated +5V	<b>Unregulated +5V</b> from the USB bus (250mA total)
N/A	20	+5V	N/A	Unregulated +5V	<b>Unregulated +5V</b> from the USB bus (250mA total)
N/A	38	+5V	N/A	Unregulated +5V	<b>Unregulated +5V</b> from the USB bus (250mA total)
N/A	56	+5V	N/A	Unregulated +5V	<b>Unregulated +5V</b> from the USB bus (250mA total)
N/A	80	+5V	N/A	Unregulated +5V	<b>Unregulated +5V</b> from the USB bus (250mA total)
3	1	GND	N/A	Ground	<b>Ground</b>
27	19	GND	N/A	Ground	<b>Ground</b>
49	37	GND	N/A	Ground	<b>Ground</b>
58	55	GND	N/A	Ground	<b>Ground</b>
65	79	GND	N/A	Ground	<b>Ground</b>
80	N/A	GND	N/A	Ground	<b>Ground</b>
93	N/A	GND	N/A	Ground	<b>Ground</b>

## Designing Hardware for QuickUSB

FX2128 Pin	QUSB2 Pin	Name	Dir	Desc	Function
116	N/A	GND	N/A	Ground	Ground
125	N/A	GND	N/A	Ground	Ground
14	N/A	NC	N/A	No Connect	This pin must be left open.
15	N/A	NC	N/A	No Connect	This pin must be left open.
16	N/A	NC	N/A	No Connect	This pin must be left open.

*Table 7 - QuickUSB Pin Definitions*

## Using the QuickUSB Library

### Overview

The QuickUSB® Library API gives programmers a cohesive programming interface to the QuickUSB family of products. The same QuickUSB Library API works for all QuickUSB products on all platforms, so you write your software once and all your QuickUSB based products will work on any supported platform.

The QuickUSB library offers support for many programming languages. The QuickUSB Library includes support for the following programming languages:

- Microsoft Visual Basic 6.0
- Microsoft C/C++ version 6.0, MFC dialog and command line
- Microsoft .NET 2003
- Borland C++ Builder 5.0
- Borland Delphi 4.0
- LabView 7.0
- Qt Designer

This API documentation is language independent. To find the particular parameter type, please consult the QuickUSB Library include files for your programming language.

There are three basic methods of interfacing with the QuickUSB Library, using a function-based API, a class-based API or a using a QuickUSB component.

The function-based API makes calls to the QuickUSB Library directly from your programming language. For instance, your application will include a file that has all the QuickUSB function declarations then from your code, you would call the appropriate functions to implement the behavior you need.

The class-based API makes the QuickUSB Library level calls from an object-oriented interface. Your code instantiates one or more CQuickUSB objects and calls the methods to implement the required behavior.

The component-based approach displays available modules and lets the user interact with the component GUI to make that selection, and then the app calls component methods to implement the required behavior.

### How to Communicate with a Module

The general procedure to use a QuickUSB module is given below:

1. Call QuickUsbFindModules to get a list of available modules. The list will be returned as a NULL-delimited string.
2. Parse the list of available modules and provide a means to select the desired module.
3. Then, for each data transaction (send or receive):
  - a. Call QuickUsbOpen and pass in the device name. A new device id is returned on success.
  - b. Call the data transfer functions needed by your application.
  - c. Call QuickUsbClose to close the handle to the USB module.

### Data Types

This document uses the following parameter data type naming convention:

BYTE	an 8-bit unsigned character
PBYTE	a pointer to a BYTE or an array of BYTES
CHAR	an 8-bit signed character
PCHAR	a pointer to a CHAR or an array of CHARs
WORD	a 16-bit unsigned integer
PWORD	a pointer to a WORD or an array of WORDs
LONG	a 32-bit signed integer
PLONG	a pointer to a LONG or an array of LONGs
ULONG	a 32-bit unsigned integer
PULONG	a pointer to a ULONG or an array of ULONGs
HANDLE	a LONG
PHANDLE	a pointer to a HANDLE

### Blocking versus Non-blocking Data Transfers

The QuickUSB Library allows a user to make both Blocking (`QuickUsbReadData` and `QuickUsbWriteData`) and Non-blocking (`QuickUsbReadDataAsync` and `QuickUsbWriteDataAsync`) data transfer calls. When called, the Blocking functions will initiate a data transfer, and will return from the function once that data transfer has completed. A Non-blocking function, when called, will initiate a data transfer and return to the program without waiting for the data transfer to complete. The user can then call `QuickUsbAsyncWait` to get the status of the data transfer or wait for the transfer to complete. For a user concerned with transferring data and processing it as quickly as possible, they will want to implement the Asynchronous Non-blocking function calls. This will allow the user to process already transferred data while collecting more data.

## QuickUSB Base API

General purpose functions to manage the operation of the QuickUSB module and the Library.

### QuickUsbFindModules

#### Purpose

Build a list of all QuickUSB modules connected to the host.

#### Parameters

**nameList:** A PCHAR that points to a buffer in which to store a of QuickUSB module names found by the library. Device names are of the form 'QUSB-XXX' where XXX is the device address (0-126) in decimal. 'nameList' must be large enough to contain all the device names + 1 character.

**length:** A LONG containing the length of the nameList buffer in CHARs.

#### Returns

A LONG that is either non-zero on success or zero (0) on failure. If successful, nameList will contain a NULL ('\0' or CHR(0)) delimited list of QuickUSB module names found by the library. The final entry is designated by two consecutive NULL characters. For example, after executing this function with one module connected, nameList will contain "QUSB-0\0\0". If there are two devices plugged in, nameList will contain "QUSB-0\0QUSB-1\0\0".

#### Notes

This routine will only find devices that are closed.

### QuickUsbOpen

#### Purpose

Open a QuickUSB device for use by the library

#### Parameters

**hDevice:** A PHANDLE that points to a HANDLE in which to place the new device ID. If successful, hDevice will contain the new HANDLE.

**devName:** A PCHAR that points to a null-terminated CHAR array containing the name of the device. Device names are of the form 'QUSB-XXX' where XXX is the device address (0-126) in decimal. The device name should be parsed from the response from QuickUsbFindModules. For example, if two modules are connected, devName should contain "QUSB-0" to select the first module, and devName should contain "QUSB-1" to select the second module.

#### Returns

A LONG that is either non-zero on success or zero (0) on failure.

#### Notes

- This function will only open devices that are closed.

## Using the QuickUSB Library

### QuickUsbClose

#### Purpose

Close a QuickUSB device.

#### Parameters

hDevice: A HANDLE that was returned from a call to QuickUsbOpen.

#### Returns

A LONG that is either non-zero on success or zero (0) on failure.

#### Notes

None.

### QuickUsbGetStringDescriptor

#### Purpose

Returns the string descriptor for the selected QuickUSB module.

#### Parameters

hDevice: A HANDLE that was returned from a call to QuickUsbOpen.

index: The BYTE string descriptor index given in the following table:

buffer: A PCHAR that points to a buffer in which to place the string descriptor. The buffer should be at least 128 bytes long.

length: A WORD that contains the length of the buffer in bytes.

Symbol	Index	Description
QUICKUSB_MAKE	1	Manufacturer String
QUICKUSB_MODEL	2	Device ID string (including firmware type and version)
QUICKUSB_SERIAL	3	Serial Number

*Table 8 - QuickUSB String Descriptors*

#### Returns

A LONG that is either non-zero on success or zero (0) on failure. This function returns a NULL terminated string in the buffer if successful.

#### Notes

None.

### QuickUsbSetTimeout

#### **Purpose**

Set the timeout for QuickUSB read data transfers.

#### **Parameters**

hDevice: A HANDLE that was returned from a call to QuickUsbOpen.  
timeout: A LONG that specifies the new timeout value in milliseconds.

#### **Returns**

A LONG that is either non-zero on success or zero (0) on failure.

#### **Notes**

- The default timeout for data transfers is 1000ms.
- The new timeout is applied immediately to all ports regardless of their state.

### QuickUsbGetDriverVersion

#### **Purpose**

Determine the version of the QuickUSB driver.

#### **Parameters**

major: A PWORD that points to a variable in which to place the major version number.  
minor: A PWORD that points to a variable in which to place the minor version number.  
build: A PWORD that points to a variable in which to place the build number.

#### **Returns**

A LONG that is either non-zero on success or zero (0) on failure.

#### **Notes**

- For Linux-based systems, this function returns the library version.

### QuickUsbGetDllVersion

#### **Purpose**

Determine the version of the QuickUSB DLL (QuickUSB.dll).

#### **Parameters**

major: A PWORD pointing to variable in which to place the major version number.  
minor: A PWORD pointing to variable in which to place the minor version number.  
build: A PWORD pointing to variable in which to place the build number.

#### **Returns**

A LONG that is non-zero on success, zero (0) on failure.

#### **Notes**

- For Linux-based systems, this function returns the library version.

### QuickUsbGetFirmwareVersion

#### Purpose

Determine the version of the QuickUSB Firmware is currently in the QuickUSB Module.

#### Parameters

- major: A PWORD pointing to variable in which to place the major version number.
- minor: A PWORD pointing to variable in which to place the minor version number.
- build: A PWORD pointing to variable in which to place the build number.

#### Returns

A LONG that is non-zero on success, zero (0) on failure.

#### Notes

- None

### QuickUsbGetLastError

#### Purpose

Return extended error information for the last API call that returned a value of FALSE (0).

#### Parameters

- error: A PLONG pointing to a variable in which to place the error code.

#### Returns

A LONG containing 1.

#### Notes

Error Code	Error Description
0	No error
1	Out of memory. Please free some memory and try again.
2	Cannot open module.
3	Cannot find specified QuickUSB module. Please check the specified module name.
4	IOCTL failed. Caused when an error is returned by the QuickUSB driver to the QuickUSB Library.
5	Cannot read or write data length of zero or greater than 16 megabytes. Cannot read or write I2C or SPI data length of zero or greater than 64 bytes. Try breaking the transfer up into smaller blocks.
6	Timeout occurred while attempting to read or write data.
7	This function is not supported by the version of the QuickUSB driver you are using. Please update your driver to the latest version.
8	I2C bus error.
9	No ACK received from I2C device.
10	An I2C slave device is holding SCL low.
11	Timeout on the I2C bus.

Table 9 - QuickUsbGetLastError Error Codes

## QuickUSB Settings

The QuickUSB module has certain settings that control the behavior of the module. These functions manipulate those settings in order to customize the module's behavior for your particular needs. A list of settings follows:

Addr	Name	Description	Values
0	SETTING_EP26CONFIG	Endpoint configuration	MSB=EP2CFG – Bit definitions: Bit 15: Valid – Activates EP2 0 = EP2 Endpoint not activated 1 = EP2 Endpoint activated Bit 14: Direction – Sets EP2 Direction 0 = Output 1 = Input Bit 13-12: Type – Defines EP2 Type 00 = Invalid 01 = Isochronous 10 = Bulk 11 = Interrupt Bit 11: Size – Sets Size of EP2 Buffer 0 = 512 Bytes 1 = 1024 Bytes Bit 10: Unused R/O = 0 Bit 9-8: Buf – EP2 Buffer Type/Amount 00 = Quad 01 = Invalid 10 = Double 11 = Triple LSB=EP6CFG – Bit definitions: Bit 15: Valid – Activates EP6 0 = EP6 Endpoint not activated 1 = EP6 Endpoint activated (default) Bit 14: Direction – Sets EP6 Direction 0 = Output 1 = Input Bit 13-12: Type – Defines EP6 Type 00 = Invalid 01 = Isochronous 10 = Bulk 11 = Interrupt Bit 11: Size – Sets Size of EP6 Buffer 0 = 512 Bytes 1 = 1024 Bytes Bit 10: Unused R/O = 0 Bit 9-8: Buf – EP6 Buffer Type/Amount 00 = Quad 01 = Invalid 10 = Double 11 = Triple

## Using the QuickUSB Library

Addr	Name	Description	Values
1	SETTING_WORDWIDE	High-speed port data width	MSB=Unused, Reserved for future use. LSB - Bit definitions: Bit 7-1: Reserved Bit 0: WORDWIDE – HSPP data width 0 = 8 bits 1 = 16 bits
2	SETTING_DATAADDRESS	Data bus starting address and flags to enable and disable 1) the address bus and 2) the feature that auto increments the bus address after each data transaction.	Bit 15: 0=Increment address bus 1=Don't increment address bus Bit 14: 0=enable address bus 1=disable address bus (port C[7:0] and E[7] may be used as general purpose I/O) Bit 13-9: Unused Bits 8-0: HSPP address value
3	SETTING_FIFO_CONFIG	Sets the FIFO configuration. Controls the FX2 IFCONFIG register.	MSB=FIPOINPOLAR -Slave FIFO Interface Pins Polarity Bit Definitions: Bit 15-14: Unused R/O = 0 Bit 13: PKTEND – FIFO Packet End Polarity 0 = Active Low 1 = Active High Bit 12: SLOE – FIFO Output Enable Polarity 0 = Active Low 1 = Active High Bit 11: SLRD – FIFO Read Polarity 0 = Active Low 1 = Active High Bit 10: SLWR – FIFO Write Polarity 0 = Active Low 1 = Active High Bit 9: EF – FIFO Empty Flag Polarity 0 = Active Low 1 = Active High Bit 8: FF – FIFO Full Flag Polarity 0 = Active Low 1 = Active High LSB=IFCONFIG – Interface Configuration Bit definitions: Bit 7: IFCLKSRC – IFCLK source select 0=External clock 1=Internal clock Bit 6: 3048MHZ – IFCLK speed select 0=30Mhz 1=48MHZ Bit 5: IFCLKOE – IFCLK output enable 0=Tri-state the IFCLK pin 1=Drive the IFCLK pin Bit 4: IFCLKPOL – IFCLK polarity select

## Using the QuickUSB Library

Addr	Name	Description	Values
			0=Normal 1=Inverted Bit 3: ASYNC – GPIF clock mode select 0=Synchronous GPIF 1=Asynchronous GPIF Bit 2: Reserved (do not change) Bit 1-0: IFCFG- HSPP Configuration 00=I/O ports 01=Reserved 10=GPIF Master mode 11=Slave FIFO mode
4	SETTING_FPGATYPE	Sets the FPGA configuration scheme	MSB=Reserved (Reads 0, Ignored if set), LSB – FPGATYPE Bit 7-1 : Reserved Bit 0 : FPGATYPE 0 = Altera Passive Serial 1 = Xilinx Slave Serial
5	SETTING_CPUCONFIG	Sets the CPU configuration. Controls the FX2 CPUCS register.	MSB= Misc Settings Bit 15: USB Bus Speed 0=Force full speed (12Mbps) 1=Allow high speed (480Mbps) Bit 14-8: Reserved for future use LSB=CPUCS – Bit definitions: Bit 7-6: Unused R/O = 0 Bit 5: Reserved (do not change) Bit 4-3: CLKSPD – CPU clock speed 00=12MHz 01=24MHz 10=48MHz 11=Reserved Bit 2: CLKINV – Invert CLKOUT 0=Normal 1=Invert CLKOUT Bit 1: CLKOE – CLKOUT output enable 0=Tri-state the CLKOUT pin 1=Drive the CLKOUT pin
6	SETTING_SPICONFIG	Configures the SPI interface	MSB=PORTECFG – Port E Alternate Configuration Bit Definitions: Bit 15: GPIFA8 – Enable GPIF Address Pin 1 = Configure PE7 as GPIFADR[8] output 0 = Configure PE7 as GPIO Bit 14-8: Reserved, do not change LSB=SpiConfig – SPI Configuration Bit definitions: Bit 7-1: Reserved for future use Bit 0: SPIENDIAN – Sets SPI bit order 0=LSBit to MSBit 1=MSBit to LSBit

## Using the QuickUSB Library

Addr	Name	Description	Values
7	SETTING_SLAVEFIFOLAS	Returns Slave FIFO flag status. Note: These flags are only significant when the FX2 is in slave FIFO mode. These flags do not reflect the polarity of the Slave Output Flags on FLAGA, FLAGB, FLAGC, and FLAGD since the polarity can be changed with the SETTING_FIFO_CONFIG register.	Bit 15-12: Reserved for future use Bit 11: RDY0 Pin Status Bit 10: Reserved for future use Bit 9: Empty Flag for EP6 (QuickUsbReadData) FIFO. Active high signal Bit 8: Full Flag for EP6 (QuickUsbReadData) FIFO. Active high signal Bit 7-4: Reserved for future use Bit 3: RDY1 pin status Bit 2: Reserved for future use Bit 1: Empty flag for EP2 (QuickUsbWriteData) FIFO. Active high signal Bit 0: Full Flag for EP2 (QuickUsbWriteData) FIFO. Active high signal.
8	SETTING_I2CTL	Configures I2C peripheral	MSB = Last I2C I/O status, read only Bits 15-8: 00000110 Bus error 00000111 No Ack 00001000 Normal completion 00001010 Slave wait 00001011 Timeout LSB=I2CTL – I2C Compatible Bus Control Bit definitions Bit 7-2: Reserved for future use Bit 1: Reserved – Do not change Bit 0: 400KHz – Sets I2C bus clock speed 0=Approx 100KHz 1=Approx 400KHz
9	SETTING_PORTA	Configures Port A default state. Reading a bit from IOA returns the logic level of the port pin that is two CLKOUT-clocks old. Writing a register bit to IOA writes to the port pin latch. The port latch value appears on the I/O pin if the corresponding OEA bit is set high.	MSB = OEA – Port A Output Enable Bit Definitions 0 = Disables output buffer 1 = Enables output buffer LSB = IOA – Port A I/O 0 = Low logic level 1 = High logic level
10	SETTING_PORTB	Configures Port B default state. Reading a bit from IOB returns the logic level of the port pin that is two CLKOUT-clocks old. Writing a register bit to IOB writes to the port pin latch. The port latch value appears on the I/O pin if the corresponding OEB bit is set high.	MSB = OEB – Port B Output Enable Bit Definitions 0 = Disables output buffer 1 = Enables output buffer LSB = IOB – Port B I/O 0 = Low logic level 1 = High logic level

## Using the QuickUSB Library

Addr	Name	Description	Values
11	SETTING_PORTC	Configures Port C default state. Reading a bit from IOC returns the logic level of the port pin that is two CLKOUT-clocks old. Writing a register bit to IOC writes to the port pin latch. The port latch value appears on the I/O pin if the corresponding OEC bit is set high.	MSB = OEC – Port C Output Enable Bit Definitions 0 = Disables output buffer 1 = Enables output buffer LSB = IOC – Port C I/O 0 = Low logic level 1 = High logic level
12	SETTING_PORTD	Configures Port D default state. Reading a bit from IOD returns the logic level of the port pin that is two CLKOUT-clocks old. Writing a register bit to IOD writes to the port pin latch. The port latch value appears on the I/O pin if the corresponding OED bit is set high.	MSB = OED – Port D Output Enable Bit Definitions 0 = Disables output buffer 1 = Enables output buffer LSB = IOD – Port D I/O 0 = Low logic level 1 = High logic level
13	SETTING_PORTE	Configures Port E default state. Reading a bit from IOE returns the logic level of the port pin that is two CLKOUT-clocks old. Writing a register bit to IOE writes to the port pin latch. The port latch value appears on the I/O pin if the corresponding OEE bit is set high.	MSB = OEE – Port E Output Enable Bit Definitions 0 = Disables output buffer 1 = Enables output buffer LSB = IOE – Port E I/O 0 = Low logic level 1 = High logic level
14	SETTING_PORTACCFG	Sets Port A & C configuration	MSB=PORTACCFG – I/O Port A Alternate Configuration Pin Definitions Bit 15: FLAGD – Flag D Alternate Configuration 1 = PA7 gives FLAGD status when in Slave Mode 0 = PA7 does not give FLAGD status in Slave Mode <i>Note: If both Bit 15 (FLAGD) and Bit 14 (SLCS) are set, PA7 will be configured to give the FLAGD status.</i> Bit 14: SLCS – Slave FIFO Chip Select Alternate Configuration 1 = PA7 configured as SLCS input in Slave Mode 0 = PA7 not configured as SLCS input in Slave Mode <i>Note: If both Bit 15 (FLAGD) and Bit 14 (SLCS) are set, PA7 will be configured to give the FLAGD status.</i> Bit 13-10: Unused Bit 9: INT1 – Interrupt 1 Alternate Configuration 1 = PA1 configured as interrupt

## Using the QuickUSB Library

Addr	Name	Description	Values
			<p>input 0 = PA1 not configured as interrupt input (default) <i>Note: INT1 is not currently used</i></p> <p>Bit 8: INTO – Interrupt 0 Alternate Configuration 1 = PA0 configured as interrupt input 0 = PA0 not configured as interrupt input (default) <i>Note: INTO is not currently used</i></p> <p>LSB=PORTCCFG – I/O Port C Alternate Configuration Pin Definitions</p> <p>Bit 7-0: GPIFA7:0 – Enable GPIF Address Pins 1 = Set these pins to “1” to configure this port to output the GPIF Address 0 = Set these pins to “0” to configure this port as Port C</p>
15	SETTING_PINFLAGS	Sets FIFO pin flag configuration	<p>MSB=PINFLAGSAB – Slave FIFO FLAGA and FLAGB Pin Configuration</p> <p>Bit 15-12: FLAGB – FLAGB Show the status of the FIFO Flag selected by programming these bits with the code given below.</p> <p>Bit 11-8: FLAGA – FLAGA shows the status of the FIFO Flag selected by programming these bits with the code given below.</p> <p>LSB=PINFLAGSCD</p> <p>Bit 7-4: FLAGD – FLAGD shows the status of the FIFO Flag selected by programming these bits with the code given below.</p> <p>Bit 3-0: FLAGC – FLAGC shows the status of the FIFO Flag selected by programming these bits with the code given below.</p> <p>FIFO Flag Select Codes: ‘0000’ = FLAGA = PF, FLAGB = FF, FLAGC = EF, FLAGD = EP2PF. The Endpoint FIFO of the PF, FF, or EF is selected by the FIFOADR[1:0] pins. ‘0001’, ‘0010’, ‘0011’ = Reserved ‘0100’ = EP2PF ‘0101’ = EP4PF ‘0110’ = EP6PF ‘0111’ = EP8PF ‘1000’ = EP2EF ‘1001’ = EP4EF ‘1010’ = EP6EF ‘1011’ = EP8EF ‘1100’ = EP2FF ‘1101’ = EP4FF ‘1110’ = EP6FF</p>

## Using the QuickUSB Library

Addr	Name	Description	Values
			'1111' = EP7FF
17	SETTING_VERSIONSPEED	Returns the CY7C68013 hardware revision and USB bus speed.	MSB= Hardware revision Bits 15-8: 00000000=CY7C68013 Rev A/B 00000001=CY7C68013A Rev A 00000010=CY7C68013 Rev C/D 00000100=CY7C68013 Rev E LSB= USB bus speed Bit 7: 0=Full Speed (12Mbps) 1=High Speed (480Mbps) Bit 6-0: Reserved for future use

*Table 10 - QuickUSB Settings*

### QuickUsbReadSetting

#### **Purpose**

To read QuickUSB module settings.

#### **Parameters**

hDevice: A HANDLE that was returned from a call to QuickUsbOpen.

address: A WORD containing the setting address (number)

setting: A PWORD pointing to a variable in which to place the value of the setting if successful.

#### **Returns**

A LONG that is non-zero and the setting value in 'setting' if successful, zero (0) otherwise.

#### **Notes**

None.

### QuickUsbWriteSetting

#### **Purpose**

To write QuickUSB module settings.

#### **Parameters**

hDevice: A HANDLE that was returned from a call to QuickUsbOpen.

address: A WORD containing the setting address.

setting: A WORD containing the new setting value.

#### **Returns**

A LONG that is non-zero on success, zero (0) on failure.

#### **Notes**

None

### QuickUsbReadDefault

#### **Purpose**

To read QuickUSB module defaults. The defaults are non-volatile and are read into the settings table on power up.

#### **Parameters**

hDevice: A HANDLE that was returned from a call to QuickUsbOpen.  
address: A WORD containing the default address (number)  
setting: A PWORD pointing to a variable in which to place the value of the default if successful.

#### **Returns**

A LONG that is non-zero on success, zero (0) on failure.

#### **Notes**

None.

### QuickUsbWriteDefault

#### **Purpose**

To write QuickUSB module defaults. The defaults are non-volatile and are read into the settings table on power up.

#### **Parameters**

hDevice: A HANDLE that was returned from a call to QuickUsbOpen.  
address: A WORD containing the default address (number)  
setting: A WORD containing the new default value.

#### **Returns**

A LONG that is non-zero on success, zero (0) on failure.

#### **Notes**

None.

## FPGA Configuration

The QuickUSB Plug-In module can configure SRAM-based FPGA devices over the USB. The default FPGATYPE is Passive Serial. For more information on changing the FPGA type, see the [SETTING FPGATYPE](#) setting of the 'Settings' section of this document.

You must convert your FPGA configuration file to binary image format for use with QuickUSB. Altera binary files are of type RBF and Xilinx are of type BIT. If you are configuring multiple devices, they must be daisy-chained and the configuration files combined in the conversion process into a single binary file.

To configure an FPGA, follow these steps:

1. Call `QuickUsbStartFpgaConfiguration`. This resets the FPGA and starts the configuration process.
2. Open the binary FPGA configuration file and read a block into a buffer.
3. Call `QuickUsbWriteFpgaData` and pass in the data from the file. Repeat this process until the entire file is sent. Of course, the last block will probably be less than the maximum block size. In addition, if you need to restart the configuration process for some reason, you can call `restart` at step 1 at any time. Be sure to close the binary FPGA configuration file when you are done.
4. Call `QuickUsbIsFpgaConfigured`. If the 'isConfigured' parameter gets set to '1', the FPGA was correctly configured. If not, try again starting at step 1.

### QuickUsbStartFpgaConfiguration

#### Purpose

Start the process of FPGA configuration. If the FPGA is in the process of being configured, the process will restart. If the FPGA is already configured, it will be reset and reconfigured.

#### Parameters

`hDevice`: A HANDLE that was returned from a call to `QuickUsbOpen`.

#### Returns

A LONG that is non-zero on success, zero (0) on failure.

#### Notes

None

### QuickUsbWriteFpgaData

#### **Purpose**

Sends FPGA configuration data to the FPGA using the QuickUSB FPGA configuration port.

#### **Parameters**

hDevice: A HANDLE that was returned from a call to QuickUsbOpen.  
data: A PBYTE pointing to a BYTE buffer containing the FPGA configuration data. See notes.  
length: A ULONG containing the length of the data in bytes. See notes.

#### **Returns**

A LONG that is non-zero on success, zero (0) on failure.

#### **Notes**

- The maximum data length is 64.
- A call to QuickUsbStartFpgaConfiguration must precede FPGA configuration.

### QuickUsbIsFpgaConfigured

#### **Purpose**

Check to see if the FPGA is configured.

#### **Parameters**

hDevice: A HANDLE that was returned from a call to QuickUsbOpen.  
isConfigured: A PWORD pointing to a WORD in which to write the configuration status of the FPGA connected to the QuickUSB FPGA configuration port. 1 = the FPGA is configured (CONF\_DONE = '1'), 0 = the FPGA is not configured (CONF\_DONE = '0').

#### **Returns**

A LONG that is non-zero on success, zero (0) on failure.

#### **Notes**

- The value of the the CONF\_DONE line is returned as bit 0 of 'isConfigured'.

## High-Speed Parallel Port

### QuickUsbReadCommand

#### Purpose

Read a block of command values from the high-speed parallel port using the QuickUSB module.

#### Parameters

- hDevice: A HANDLE that was returned from a call to QuickUsbOpen.
- address: A WORD containing the address. This address is the starting value of the HSPP address bus. If address bit 14 is set (1), then the address bus will not be driven. If address bit 15 is set (1), then the address will not be incremented after each read.
- data: A pointer to a buffer in which to place data read from the high-speed parallel port. See *notes*.
- length: A PWORD pointing to a WORD containing the number of **bytes** to read from the high-speed parallel port on input and the number of **bytes** read on return. See *notes*.

#### Returns

A LONG that is non-zero on success, zero (0) on failure.

#### Notes

- The maximum length is 64 bytes.
- The data buffer can contain data values of any type.
- Commands are transferred over the high-speed parallel port with the CMD\_DATA line set to '1'.
- The address bus behavior for data transfers is defined by the [SETTING\\_DATAADDRESS](#) setting.

### QuickUsbWriteCommand

#### Purpose

Write a block of command values to the high-speed parallel port using the QuickUSB module.

#### Parameters

- hDevice: A HANDLE that was returned from a call to QuickUsbOpen.
- address: A WORD containing the address. This address is the starting value of the HSPP address bus. If address bit 14 is set (1), then the address bus will not be driven. If address bit 15 is set (1), then the address will not be incremented after each write.
- data: A pointer to a buffer containing the data to write to the high-speed parallel port. See *notes*.
- length: A WORD containing the number of **bytes** to write to the high-speed parallel port. See *notes*.

#### Returns

A LONG that is non-zero on success, zero (0) on failure.

#### Notes

- The maximum length is 64 bytes.
- The data buffer can receive data values of any type.
- Commands are transferred over the high-speed parallel port with the CMD\_DATA line set to '1'.
- The address bus behavior for data transfers is defined by the [SETTING\\_DATAADDRESS](#) setting.

## QuickUsbReadData

### Purpose

Read a block of data values from the high-speed parallel port using the QuickUSB module.

### Parameters

- hDevice: A HANDLE that was returned from a call to QuickUsbOpen.
- data: A pointer to a buffer in which to place data values read from the HSPP. *See notes.*
- length: A PULONG to a ULONG containing the number of **bytes** to read from the HSPP. *See notes.*

### Returns

A LONG that is non-zero on success, zero (0) on failure.

### Notes

- The maximum length is 16 megabytes (16777216 bytes).
- The data buffer can receive data values of any type.
- This function has a call latency of approximately 1ms for full-speed connections and 250 us for hi-speed connections.
- In order to obtain the maximum performance, call this function with the largest appropriate length value. Each call to this function will incur one call latency delay regardless of the transfer size. So to minimize delays that erode the data transfer rate, make the transfers as large as possible for your application.
- In master mode, data values are transferred over the high-speed parallel port with the CMD\_DATA line set to '0'.
- In slave mode, the USB will wait for 'length' transfers to occur before returning. If the target interface does not write length transfers to the slave FIFOs, the call will return with a value of 0 and set the last error status to QUICKUSB\_ERROR\_TIMEOUT after the timeout value specified by the QuickUsbSetTimeout function.
- The address bus behavior for data transfers is defined by the SETTING\_DATAADDRESS setting.

### QuickUsbWriteData

#### Purpose

Write a block of data values to the high-speed parallel port using the QuickUSB module.

#### Parameters

- hDevice: A HANDLE that was returned from a call to QuickUsbOpen.
- data: A pointer to a block of data values to write to the HSPP. See *notes*.
- length: A ULONG containing the number of **bytes** to write to the HSPP. See *notes*.

#### Returns

A LONG that is non-zero on success, zero (0) on failure.

#### Notes

- The maximum length is 16 megabytes (16777216 bytes).
- The data buffer can contain data values of any type.
- In master mode, data values are transferred over the high-speed parallel port with the CMD\_DATA line set to '0'.
- In slave mode, the USB will hang and wait for 'length' transfers to occur before returning. If the target interface does not read length transfers from the slave FIFOs, the call will return with a value of 0 and set the last error status to QUICKUSB\_ERROR\_TIMEOUT after the timeout value specified by the QuickUsbSetTimeout function.
- The address bus behavior for data transfers is defined by the [SETTING\\_DATAADDRESS](#) setting.

## QuickUsbReadDataAsync

### Purpose

Read a block of data values from the high-speed parallel port using an asynchronous function call.

### Parameters

- hDevice: A HANDLE that was returned from a call to QuickUsbOpen.
- data: A pointer to a buffer in which to place data read from the HSPP. See *notes*.
- length: A ULONG containing the number of **bytes** to read from the HSPP. See *notes*.
- transaction: A PBYTE to a BYTE in which to place the transaction identifier required by QuickUsbAsyncWait.

### Returns

A LONG that is non-zero on success, zero (0) on failure.

### Notes

- QuickUSB asynchronous function calls return immediately and must be followed by a call to QuickUsbAsyncWait to determine when the transaction actually completes and to free internal buffers used by the operating system. Failure to follow this procedure will result in a memory leak and an eventual system crash.
- The maximum length is 16 megabytes (16777216 bytes).
- The data buffer can receive data values of any type.
- In master mode, data values are transferred over the high-speed parallel port with the CMD\_DATA line set to '0'.
- In slave mode, the USB will hang and wait for 'length' transfers to occur before returning. If the target interface does not read length transfers from the slave FIFOs, the call will return with a value of 0 and set the last error status to QUICKUSB\_ERROR\_TIMEOUT after the timeout value specified by the QuickUsbSetTimeout function.
- The address bus behavior for data transfers is defined by the [SETTING\\_DATAADDRESS](#) setting.
- There is a global maximum of 253 asynchronous reads and writes outstanding at any time for all QuickUSB modules in the system.
- This function is not yet supported for Linux-based systems.

### QuickUsbWriteDataAsync

#### Purpose

Write a block of data values to the high-speed parallel port using an asynchronous function call.

#### Parameters

**hDevice:** A HANDLE that was returned from a call to QuickUsbOpen.  
**data:** A pointer to a block of data values to write to the HSPP. See *notes*.  
**length:** A ULONG containing the number of **bytes** to write to the HSPP. See *notes*.  
**transaction:** A PBYTE to a BYTE in which to place the transaction identifier required by QuickUsbAsyncWait.

#### Returns

A LONG that is non-zero on success, zero (0) on failure.

#### Notes

- QuickUSB asynchronous function calls return immediately and must be followed by a call to QuickUsbAsyncWait to determine when the transaction actually completes and to free internal buffers used by the operating system. Failure to follow this procedure will result in a memory leak and an eventual system crash.
- The maximum length is 16 megabytes (16777216 bytes).
- The data buffer can receive data values of any type.
- In master mode, data values are transferred over the high-speed parallel port with the CMD\_DATA line set to '0'.
- In slave mode, the USB will hang and wait for 'length' transfers to occur before returning. If the target interface does not read length transfers from the slave FIFOs, the call will return with a value of 0 and set the last error status to QUICKUSB\_ERROR\_TIMEOUT after the timeout value specified by the QuickUsbSetTimeout function.
- The address bus behavior for data transfers is defined by the [SETTING\\_DATAADDRESS](#) setting.
- There is a global maximum of 253 asynchronous reads and writes outstanding at any time for all QuickUSB modules in the system.
- This function is not yet supported for Linux-based systems.

### QuickUsbAsyncWait

#### **Purpose**

Wait for an asynchronous transfer to complete.

#### **Parameters**

hDevice: A HANDLE that was returned from a call to QuickUsbOpen.

length: An ULONG containing the number of **bytes** that were requested in the initial asynchronous function call.

transaction: A BYTE transaction identifier returned by QuickUsbReadDataAsync or QuickUsbWriteDataAsync.

immediate: A BYTE value. If nonzero, the driver will not wait the default timeout value for the transaction to complete. If zero, the driver will wait the default timeout period for the transaction to complete.

#### **Returns**

A LONG that is non-zero on success, zero (0) on failure.

#### **Notes**

- This function is not yet supported for Linux-based systems.

### General-Purpose I/O

There are five (5) 8-bit general-purpose I/O ports on the QuickUSB module named A-E. Of those, some may be used for other purposes. Port E is used for the FPGA configuration and SPI functions, so if either of these functions is used in your design, some of the pins on port E will be consumed.

Other than that, the general-purpose I/O ports are just like I/O ports you would find on a microcontroller. The functions provided by the QuickUSB Library give you the capability to set the direction of each pin, read and write to the ports on a byte wide basis.

#### QuickUsbReadPortDir

##### **Purpose**

Read the data direction of each data port bit for the specified port.

##### **Parameters**

- hDevice: A HANDLE that was returned from a call to QuickUsbOpen.
- address: A BYTE containing the port address. Ports are addressed 0 to 4 corresponding to port A-E.
- data: A PBYTE to a BYTE in which to place the data direction bit values. Each bit in data corresponds to data bits of the specified port. A data direction bit value of 0=input and 1=output (i.e. 0x03 means that bits 0 and 1 are outputs and bits 2-7 are inputs).

##### **Returns**

A LONG that is non-zero on success, zero (0) on failure.

##### **Notes**

None

#### QuickUsbWritePortDir

##### **Purpose**

Set the data direction of each data port bit for the specified port.

##### **Parameters**

- hDevice: A HANDLE that was returned from a call to QuickUsbOpen.
- address: The port address. Ports are addressed 0 to 4 corresponding to port A-E.
- data: A byte that contains the data direction bit values. Each bit in data corresponds to data bits of the specified port. A data direction bit value of 0=input and 1=output.

##### **Returns**

A LONG that is non-zero on success, zero (0) on failure.

##### **Notes**

None

### QuickUsbReadPort

#### **Purpose**

Read a series of bytes from the specified port.

#### **Parameters**

- hDevice: A HANDLE that was returned from a call to QuickUsbOpen.
- address: The port address. Ports are addressed 0 to 4 corresponding to port A-E.
- data: A pointer to an array of bytes in which to place the data. This buffer must be at least 'length' bytes long.
- length: A pointer to the number of bytes to read from the port. The bytes are read sequentially. The maximum length is 64 bytes.

#### **Returns**

A non-zero value if successful, 0 otherwise. Also returns the read value in value if successful. Otherwise value is not modified.

#### **Notes**

None

### QuickUsbWritePort

#### **Purpose**

None

#### **Parameters**

- hDevice: A HANDLE that was returned from a call to QuickUsbOpen.
- address: The port address. Ports are addressed 0 to 4 corresponding to port A-E.
- data: A pointer to an array of bytes to send out the port. This buffer must be at least 'length' bytes long.
- length: A pointer to the number of bytes to write to the port. The bytes are written sequentially. The maximum length is 64 bytes.

#### **Returns**

A non-zero value if successful, 0 otherwise.

#### **Notes**

None

### RS-232

The RS-232 ports are interrupt-driven for transmit and receive. The QuickUSB RS232 receive buffers are 128 bytes deep, so your software just needs to service these buffers often enough to make sure they do not overflow.

#### QuickUsbSetRs232BaudRate

##### **Purpose**

Set the baud rate for both serial ports. Baud rates are programmable from 4800 to 230k baud. This function sets the baud rate of both serial ports. It is not possible to set the baud rate of each serial port independently.

##### **Parameters**

hDevice: A HANDLE that was returned from a call to QuickUsbOpen.  
baudRate: An unsigned long integer (32-bits) containing the baud rate in bits per second.

##### **Returns**

A non-zero value if successful, 0 otherwise.

##### **Notes**

None

#### QuickUsbGetNumRS232

##### **Purpose**

Read the number of characters waiting in the receive buffer.

##### **Parameters**

hDevice: A HANDLE that was returned from a call to QuickUsbOpen.  
portNum: The serial port number. Serial port 0 (P1) = 0, serial port 1 (P2) = 1.  
length: A pointer to the number of characters to read. Set to the number of characters actually read on return.

##### **Returns**

A non-zero value and the number of outstanding characters if successful, 0 otherwise.

##### **Notes**

None.

### QuickUsbFlushRS232

#### **Purpose**

Flush the RS232 port transmit and receive buffers.

#### **Parameters**

hDevice: A HANDLE that was returned from a call to QuickUsbOpen.

portNum: The serial port number. Serial port 0 (P1) = 0, serial port 1 (P2) = 1.

#### **Returns**

A non-zero value if successful, 0 otherwise.

#### **Notes**

None.

### QuickUsbReadRS232

#### **Purpose**

Read a block of characters from the interrupt receive buffer of the specified QuickUSB serial port.

#### **Parameters**

hDevice: A HANDLE that was returned from a call to QuickUsbOpen.

portNum: The serial port number. Serial port 0 (P1) = 0, serial port 1 (P2) = 1.

data: A pointer to a buffer in which to place the data. The buffer must be at least 128 bytes long.

length: A pointer to the number of characters to read. Set to the number of characters actually read on return.

#### **Returns**

A non-zero value, the data and the length if successful, 0 otherwise.

#### **Notes**

- The interrupt buffer is 128 bytes deep. If length is set to more than 128, the routine will hang and wait for the specified number of characters to be read from the port before returning.

### QuickUsbWriteRS232

#### **Purpose**

Write a block of characters to the specified QuickUSB serial port.

#### **Parameters**

hDevice: A HANDLE that was returned from a call to QuickUsbOpen.

portNum: The serial port number. Serial port 0 (P1) = 0, serial port 1 (P2) = 1.

data: A pointer to a buffer containing the data.

length: The number of characters to write.

#### **Returns**

A non-zero value if successful, 0 otherwise.

#### **Notes**

- None

## I2C-Compatible Port

The QuickUSB I<sup>2</sup>C-compatible port is a master-only bus controller. The bus runs at approximately 100Khz. Address 1 is reserved. The bus speed may be changed with the [SETTING\\_I2CTL](#) setting.

### QuickUsbReadI2c

#### **Purpose**

None

#### **Parameters**

hDevice: A HANDLE that was returned from a call to QuickUsbOpen.  
address: The device address.  
data: A pointer to a buffer in which to place the data.  
length: The length of the data buffer in bytes. The maximum length is 64 bytes.

#### **Returns**

A non-zero value if successful, 0 otherwise. In addition, length is set the actual number of bytes read.

#### **Notes**

None

### QuickUsbWriteI2c

#### **Purpose**

None

#### **Parameters**

hDevice: A HANDLE that was returned from a call to QuickUsbOpen.  
address: The device address.  
data: A pointer to the data to send.  
length: The length of the data buffer in bytes. The maximum length is 64 bytes.

#### **Returns**

A non-zero value if successful, 0 otherwise.

#### **Notes**

None

### SPI-Compatible Port

The QuickUSB module implements a 'soft' SPI port using pins on port E and optionally port A. These routines support from 1 to 10 devices with individual slave select lines for each device. The slave select lines are active low and are shown in [Table 7 - QuickUSB Pin Definitions](#). The signals are MOSI, SCK, MISO and nSS0-9. By default, data is shifted in and out MSbit to LSbit. The bit shift order can be configured by changing Bit 0 of the [SETTINGS.SPICONFIG](#) setting. The SPI bus runs at approximately 500Kbps. You can learn more about QuickUSB's SPI interface in the [SPI](#) section of this document.

#### QuickUsbReadSpi

##### Purpose

Read a block of bytes from the specified SPI slave port.

##### Parameters

hDevice: A HANDLE that was returned from a call to QuickUsbOpen.  
portNum: The SPI device address (nSS line) to read from.  
data: A pointer to a buffer in which to place the received data.  
length: A pointer to the number of bytes to read. The maximum length is 64 bytes.

##### Returns

A non-zero value if successful, 0 otherwise. In addition, the data buffer is filled with the received data and the length is set to the number of bytes actually received on success. Both data and length are left unchanged if the function failed.

##### Notes

This function applies a logic low (0) to the MOSI port while reading in the data.

#### QuickUsbWriteSpi

##### Purpose

Write a block of bytes to the specified SPI slave port.

##### Parameters

hDevice: A HANDLE that was returned from a call to QuickUsbOpen.  
portNum: The SPI device address (nSS line) to write to.  
data: A pointer to the data to send.  
length: The number of bytes to send. The maximum length is 64 bytes.

##### Returns

A non-zero value if successful, 0 otherwise.

##### Notes

This function ignores data received at the MISO pin while writing. If you need to capture MISO data while writing, you should use the [QuickUsbWriteReadSpi](#) function.

### QuickUsbWriteReadSpi

#### **Purpose**

Simultaneously write and read a block of data to and from the specified SPI slave port.

#### **Parameters**

hDevice: A HANDLE that was returned from a call to QuickUsbOpen.

portNum: The SPI device address (nSS line) to write to and read from

data: A pointer to the buffer that contains the data to send and in which to place the received data.

length: The number of bytes to send and receive. The maximum length is 64 bytes.

#### **Returns**

A non-zero value if successful, 0 otherwise. In addition, the data buffer is filled with the received data and the length is set to the number of bytes actually received on success. Both data and length are left unchanged if the function failed.

#### **Notes**

This function uses the data buffer for both writing data to the SPI and to store read data from the SPI. Therefore, the data buffer will always be overwritten on each call to this function.

## Index

address bus .....	4
architecture.....	1
ASYNC.....	19
asynchronous function calls.....	2
bus	
address.....	4
high-speed parallel.....	4
CMD_DATA.....	5
current limiting.....	3
defaults	
firmware .....	4
delay	
interpacket.....	2
device .....	1
endpoint .....	1
EZ USB FX2 .....	3
FET	
power.....	3
frame .....	2
full speed.....	2
function	
asynchronous.....	2
GPIF .....	5
Ground.....	3
Hardware.....	3
High Speed Parallel Port.....	4
Hi-Speed .....	2
host.....	1
HSPP .....	4
hub	
USB .....	3
I/O connections	
GPIF master mode.....	6
slave FIFO.....	16
I/O model	
block handshake .....	12
fifo handshake .....	9
full handshake .....	11
pipeline.....	14
slave FIFO.....	16
synchronous slave FIFO .....	17
I/O Model	
simple.....	7
I/O Models	
master mode.....	6
I/O Pins	
unused .....	4
IFCLK .....	5
interpacket delay.....	2
interrupt .....	1
latency.....	2
master .....	1
mode	
GPIF master .....	5
OE5	
pipe.....	1
Power.....	3
power supply	
external .....	3
QuickUsbReadCommand.....	5
QuickUsbReadData .....	5
QuickUsbWriteCommand.....	5
QuickUsbWriteData .....	5
READY .....	11
REN.....	5
settings	
default.....	4
SETTING_DATAADDRESS.....	4
SETTING_FIFO_CONFIG ....	4, 16
SETTING_SLAVEFIFOFLAGS..	16
Simple I/O Model .....	7
Slave FIFO I/O Models .....	16
SW_PG .....	3
switch	
power.....	3
synchronous .....	5
throughput .....	2
timebase .....	2
timing parameters	
GPIF master mode .....	6
timing Parameters	
synchronous slave FIFO .....	18
TPS2051A.....	3
transfer latency .....	2
transfers	
command.....	5
data .....	5
USB.....	1
VBUS.....	3
web site .....	1
WEN .....	5
WORDWIDE.....	4